



# LATORRE

ASCENSIÓN LATORRE



THE MATERIAL THAT DREAMS ARE MADE OF





LATORRE

ASCENSIÓN LATORRE



“El material con el que se forjan los sueños “  
 “The material that dreams are made of”

A mediados del siglo XX aparece un nuevo concepto en el diseño de mueble clásico, el estilo de vanguardia. La firma Latorre comienza en 1959 de la mano de Ascensión, joven decoradora que tiene en la incipiente industria española todo un mundo para innovar. Funda su empresa en Alboraiá, un pueblo de Valencia entre la huerta y el mar. Como los agricultores que cuidan la tierra con cariño y esmero, que conciben la estética del campo más allá de la productividad como si de jardineros se tratase, Ascensión Latorre comienza a diseñar y fabricar sillas clásicas con el sello indiscutible del lujo y la calidad.

Sus productos destilan exclusividad, provocan sensaciones, emanan elegancia y buen gusto. Son la máxima representación del romanticismo de épocas pasadas con un toque actual.

El trabajo minucioso y artesanal, único, de pureza estética, ha ido madurando a lo largo de más de cincuenta años, y ha creado la marca inconfundible de Latorre. Como mujer y empresaria no dejará que su labor se pierda y sus hijos, siguiendo sus pasos se incorporan a la tradición familiar a partir de los años ochenta. El trabajo a mano, la calidez, las texturas, los pequeños detalles y los tonos suaves de sus muebles forman la propia identidad de una empresa que crece sin parar.

Guillermo, el primer hijo del matrimonio Latorre trabaja en la empresa desde 1985 como director comercial, siendo en la actualidad director de arte, y su hermano Kiko se incorpora en 1994 avalado por sus estudios financieros. Pau aparece en la empresa familiar a finales de la década de los noventa, es ingeniero informático y con sus conocimientos transforma y moderniza todos los procesos de fabricación. Aplica la norma ISO 9001 no solo en gestión sino también en la producción de muebles. Con ella no sólo se dota a la empresa de los estrictos estándares de calidad, sino que se sitúa a la cabeza de un sector en auge.

La tercera generación de la familia Latorre continúa con Guillem, nieto de Ascensión, que se encarga de reforzar la presencia de Latorre en el extranjero identificándose ya en todo el mundo como referente del diseño clásico de vanguardia.

Ascensión, la joven decoradora, sigue manteniendo viva el alma de la empresa. Jubilada, orgullosa de su obra que jamás ha perdido vigencia sigue con elegancia y buen gusto, asesorando a su familia en la búsqueda constante de la belleza, en la creación de nuevas piezas singulares, obras maestras que penetran por los sentidos y nos acompañan a lo largo de nuestra vida.

A new concept in classical furniture design, the avant-garde style, emerged in the mid-20th century. The firm Latorre was established in 1959 by Ascensión, a young decorator who discovered in the fledgling Spanish industry an entire world in which to innovate. She founded her company in Alboraiá, a town in the Valencian Region between the huerta, a traditional agricultural area around the city of Valencia, and the sea. Like the farmers who look after the soil with love and care, who want to make their fields attractive rather than merely productive as if they were gardeners, Ascensión Latorre began to design and manufacture classical chairs with an unquestionable stamp of luxury and quality. Its products are steeped in exclusivity, evoke sentiment and exude elegance and good taste. They are the epitome of a romantic bygone era yet have a contemporary twist. Unique, meticulous craftsmanship with an immaculate appearance which has evolved over more than fifty years to create the unmistakable Latorre brand.

As a woman and entrepreneur Ascensión was determined not to let her work go to waste, and encouraged her children to follow in her footsteps. They joined the family tradition in the 1980s. The decade saw the company export its new creations to France and Portugal, items whose soul would be exclusivity. Excellence in manufacturing and the warmth, textures, small details and subtle shades of its furniture make up the identity of a company that is constantly growing. Guillermo, the family's eldest son, has been working in the company since 1985 as its sales director and is now also its art director. His brother Kiko joined in 1994 after completing his studies in finance. Pau came into the family firm in the late 1990s and has used his skills as a computer engineer to upgrade all its manufacturing processes. Both management and furniture production are ISO 9001 certified. This means the company operates to exacting quality standards and is also at the forefront of a booming sector.

The third generation of the Latorre family continues with Guillem, Ascensión's grandson, who is in charge of boosting Latorre's presence abroad where it is identified worldwide as a benchmark for avant-garde classical design.

Ascensión, the young decorator, still keeps the soul of the company alive. Proud of her work that has never lost its up-to-date appeal, she continues to advise her family with elegance and exquisite taste in a constant search for beauty. This also includes creating new unique items, masterpieces that penetrate through the senses and stay with us throughout our lives.



LATORRE COLLECTION

  
**LATORRE**  
ESTABLISHED 1870

## INDEX

- 006 SOFAS
- 142 CHAISE LONGUES
- 156 WINGCHAIRS
- 176 ARMCHAIRS & EASY CHAIRS
- 200 COFFEE TABLES & STOOLS
- 228 DINING & BAR CHAIRS
- 250 TABLES
- 264 BOOKCASES
- 266 BED
- 268 COMPLEMENTS

TECHNICAL INFORMATION



“Silencio cómodo...  
...estamos creando”  
“Comfortable silence...  
...we’re creating”

SOFAS

008 GRAND NATIONAL

022 MAYFAIR

038 CHUKKA

050 ASCOT

058 BOND

062 ROYALTON BRIDE

074 FLOFÀ

088 CHARLES XXL

100 CHARLES

104 CHARLES BED

110 DANTE

118 SIMPSON COUNTRY

128 MORRISON COUNTRY

132 VENDÔME



LATORRE COLLECTION

## GRAND NATIONAL

---

LATORRE DESIGN DEPARTMENT

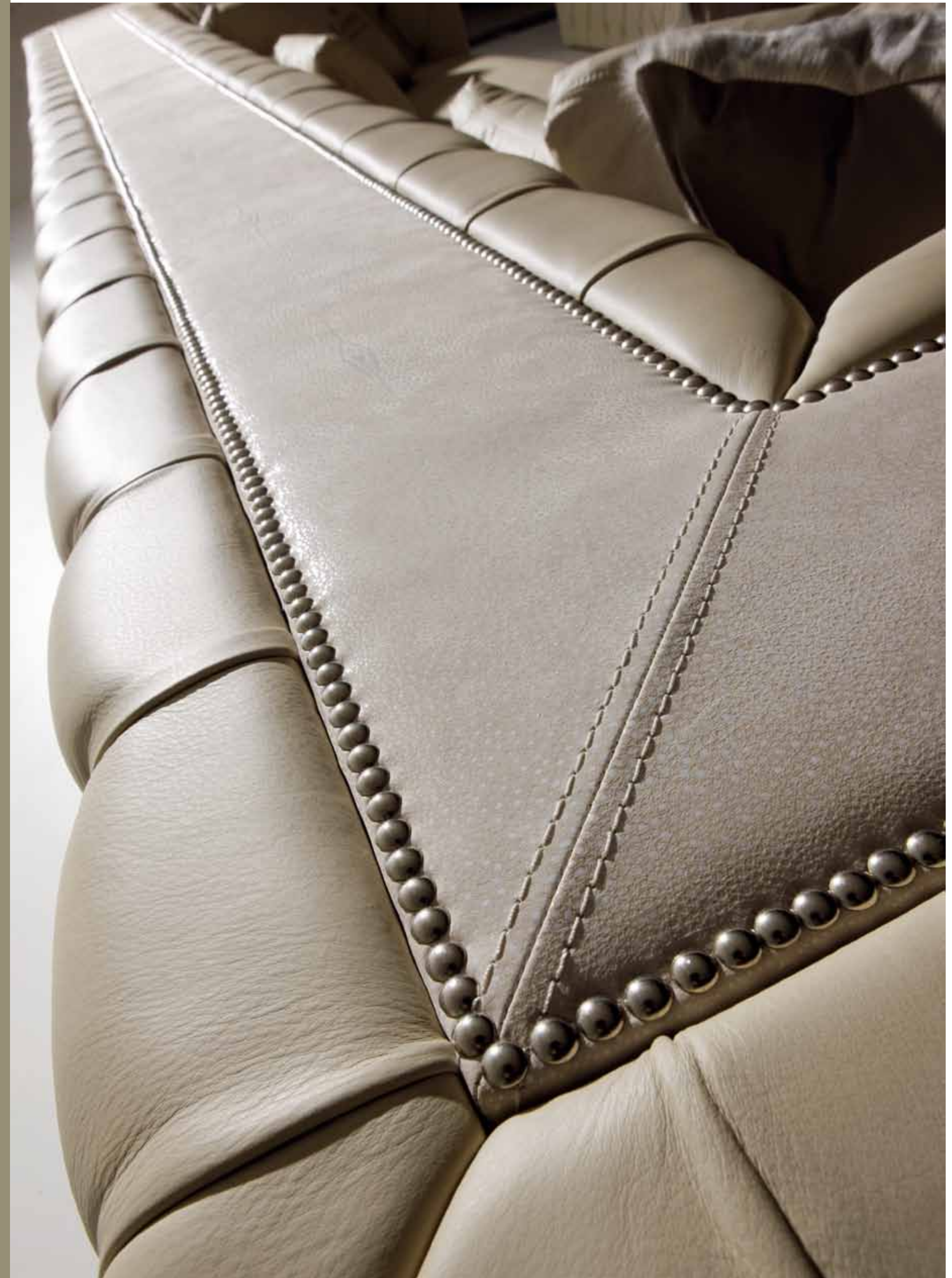













GRAND NATIONAL AMAZING MODULAR Sofa

ODENSE Low chair

KNIGHTSBRIDGE Coffee Table

ANGELICA PALE Carpet







GRAND NATIONAL AMAZING MODULAR Sofa

KNIGHTSBRIDGE Coffee table

VERMONT Telescopic coffee table

ANGELICA PALE Carpet



LATORRE COLLECTION

# MAYFAIR

---

DESIGN GUILLERMO T











026 LATORRE SOFAS



MAYFAIR Armchair





MAYFAIR Stool

DOLOMITA Coffee & side table

VENICE Table lamp

GENTLEMAN Carpet





030 LATORRE SOFAS



MAYFAIR MODULAR Sofa







2012 ADVERTISING CAMPAIGN ART DIRECTOR GUILLERMO T PHOTOGRAPH PEDRO LLORCA



LATORRE COLLECTION

# CHUKKA

---

DESIGN ROLF ZIMMERMANN











CHUKKA MODULAR Sofa

CHUKKA Footstool ( special plaited pipping )

CHUKKA Small and pet tray

CHUKKA Arm stool

LINX RABBIT Plaid & cushions





044 LATORRE SOFAS



CHUKKA Modular sofa

CHUKKA Footstool (special platted piping)

CHUKKA Pet tray







LATORRE COLLECTION

## ASCOT

---

DESIGN GUILLERMO T

















LATORRE COLLECTION

## BOND

---

DESIGN GUILLERMO T







060 LATORRE SOFAS

BOND MODULAR Sofa & armchair  
AINSLEY Coffee table  
GENTLEMAN WHITE Carpet  
WHITE Plaid



LATORRE COLLECTION

## ROYALTON BRIDE

---

DESIGN GUILLERMO T







ROYALTON BRIDE Sofa

STAFFORD Coffee table

LOW NIGHTINGALE Armchair

CASANDRA LARGE Roof lamp

LINX RABITT Plaid

LINX RABITT Cushion





066 LATORRE SOFAS

ROYALTON BRIDE Sofa

STAFFORD Coffee table

LINX RABITT Plaid

LINX RABITT Cushion





070 LATORRE SOFAS



ROYALTON BRIDE Sofa







LATORRE COLLECTION

# FLOFÀ

---

DESIGN CRISTINA GORZANELLI







FLOFÀ Sofa

DOLOMITA Side table

VENICE Table lamp

GENTLEMAN WHITE Carpet



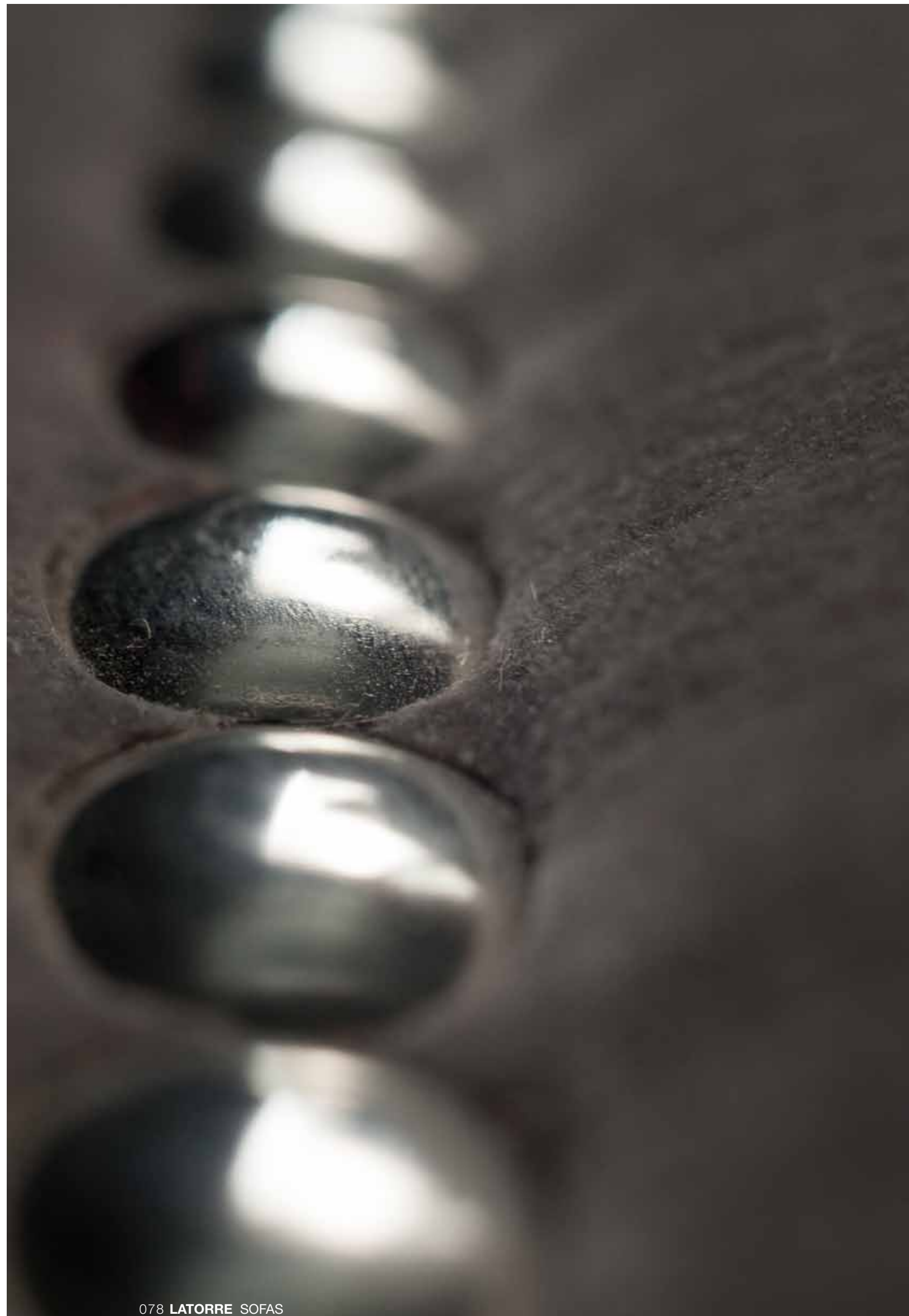

078 LATORRE SOFAS



FLOFÀ Armchair

GENTLEMAN WHITE Carpet





FLOFÀ Sofa  
FLOFÀ Armchair  
DOLOMITA Coffee & side table  
VENICE Table lamp  
GENTLEMAN WHITE Carpet



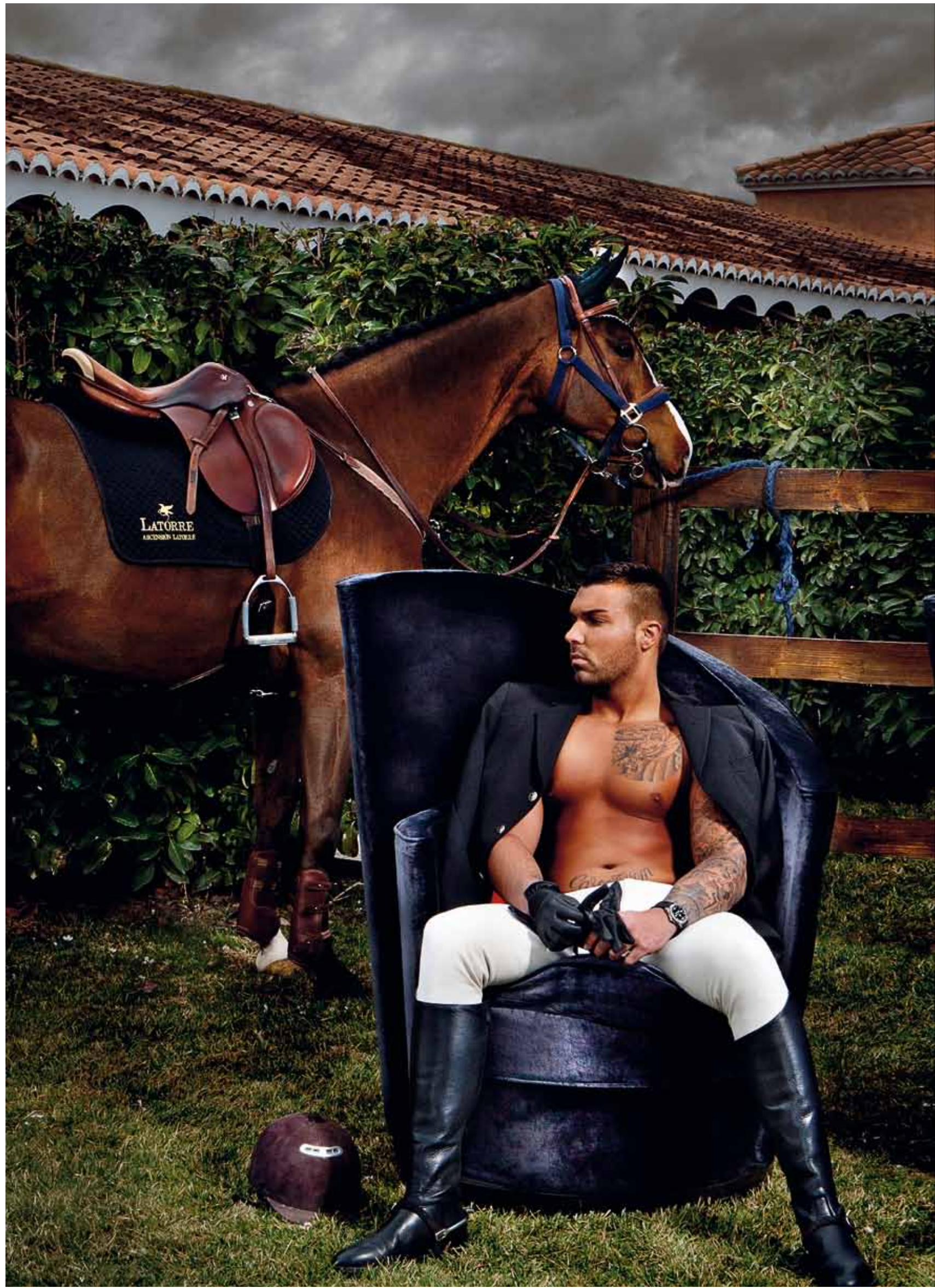











LATORRE COLLECTION

## CHARLES XXL

---

DESIGN GUILLERMO T

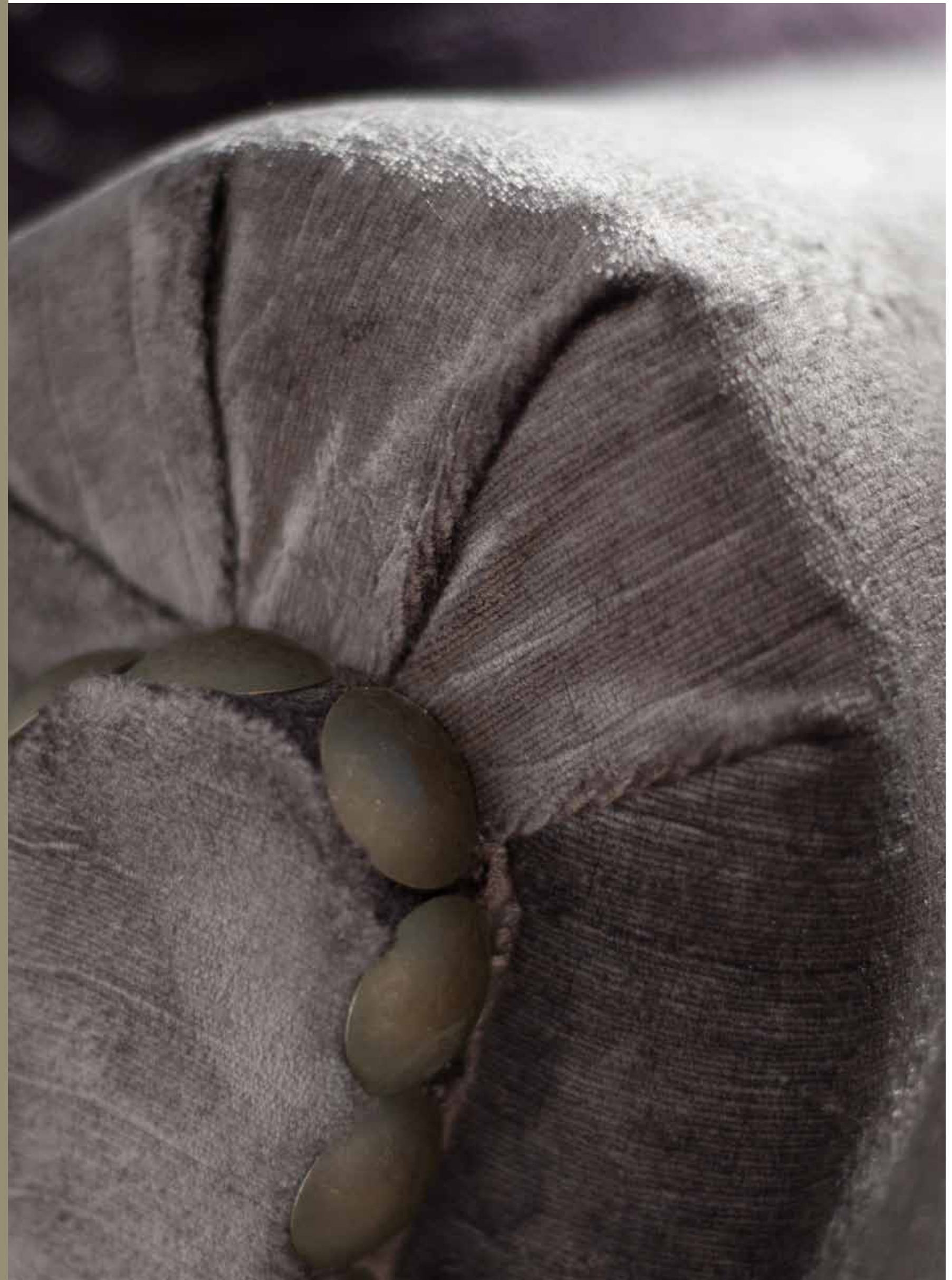





090 LATORRE SOFAS



STAFFORD Coffee table















LATORRE COLLECTION

# CHARLES

---

DESIGN GUILLERMO T

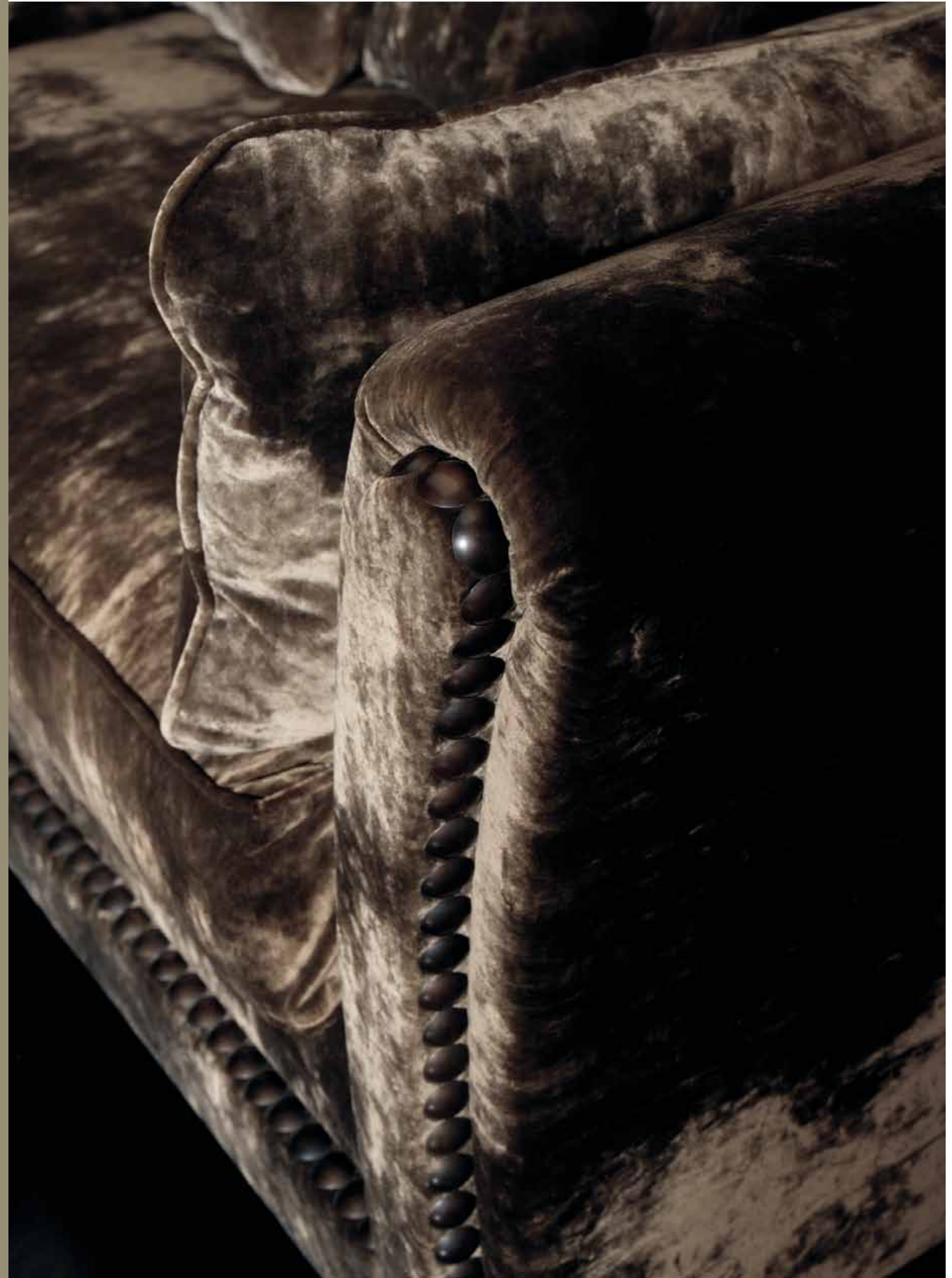









CHARLES Bed sofa

DOLOMITA Coffee table

GENTLEMAN WHITE Carpet

ETNA Lamp











LATORRE COLLECTION

## DANTE

---

DESIGN GUILLERMO T

















LATORRE COLLECTION

## SIMPSON COUNTRY

---

DESIGN GUILLERMO T





















LATORRE COLLECTION

## MORRISON COUNTRY

---

DESIGN GUILLERMO T

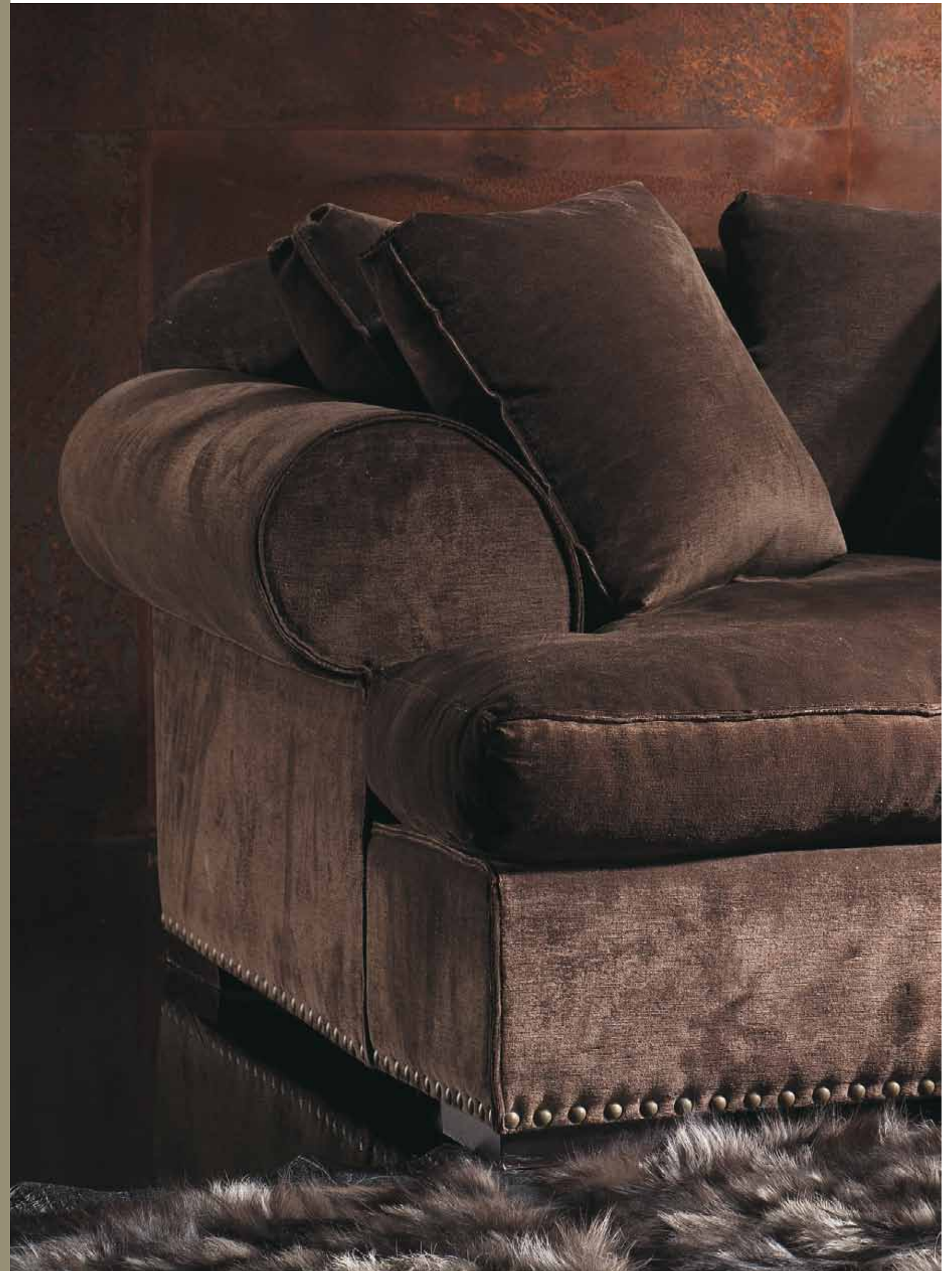



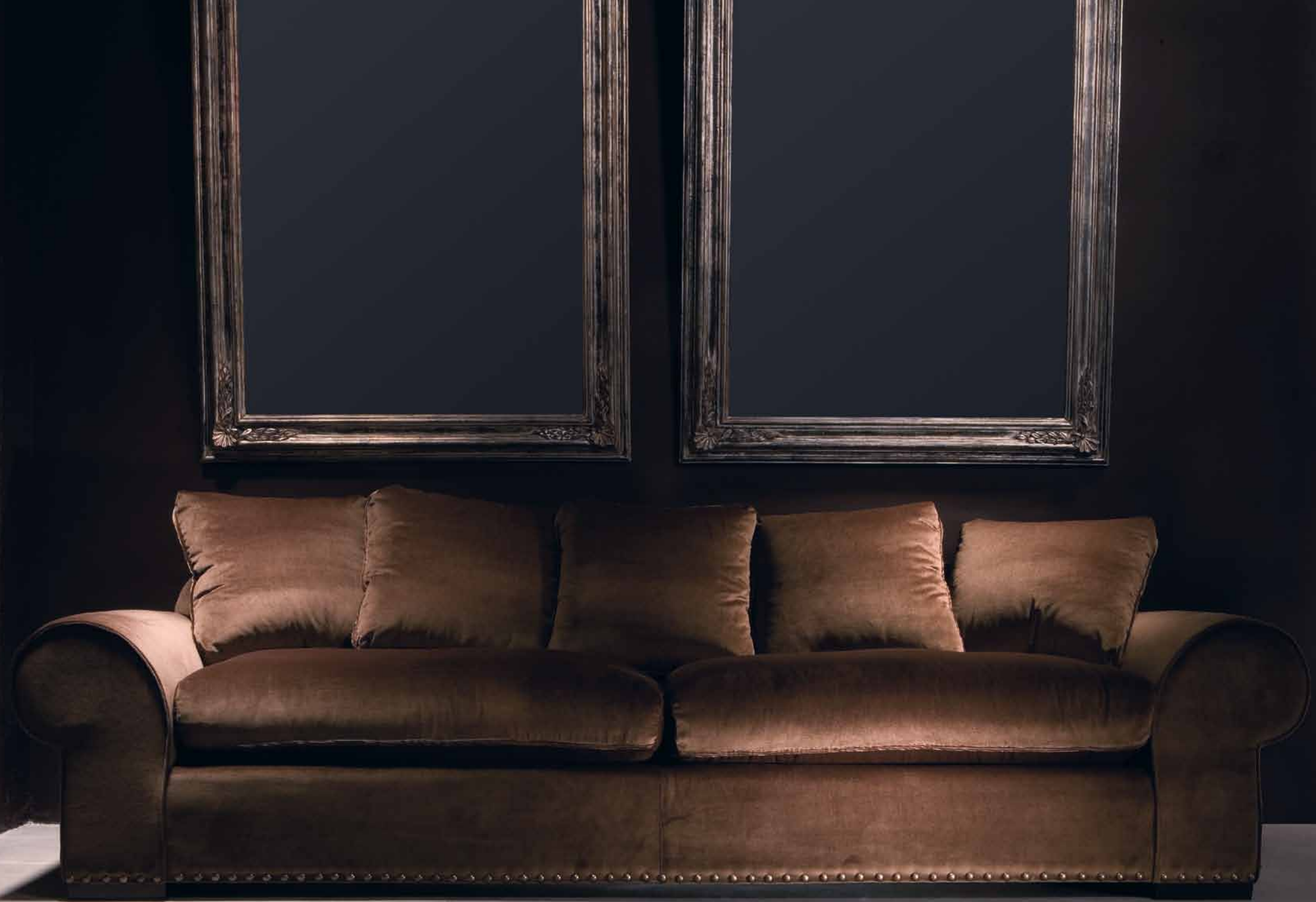



LATORRE COLLECTION

# VENDÔME

---

DESIGN GUILLERMO T

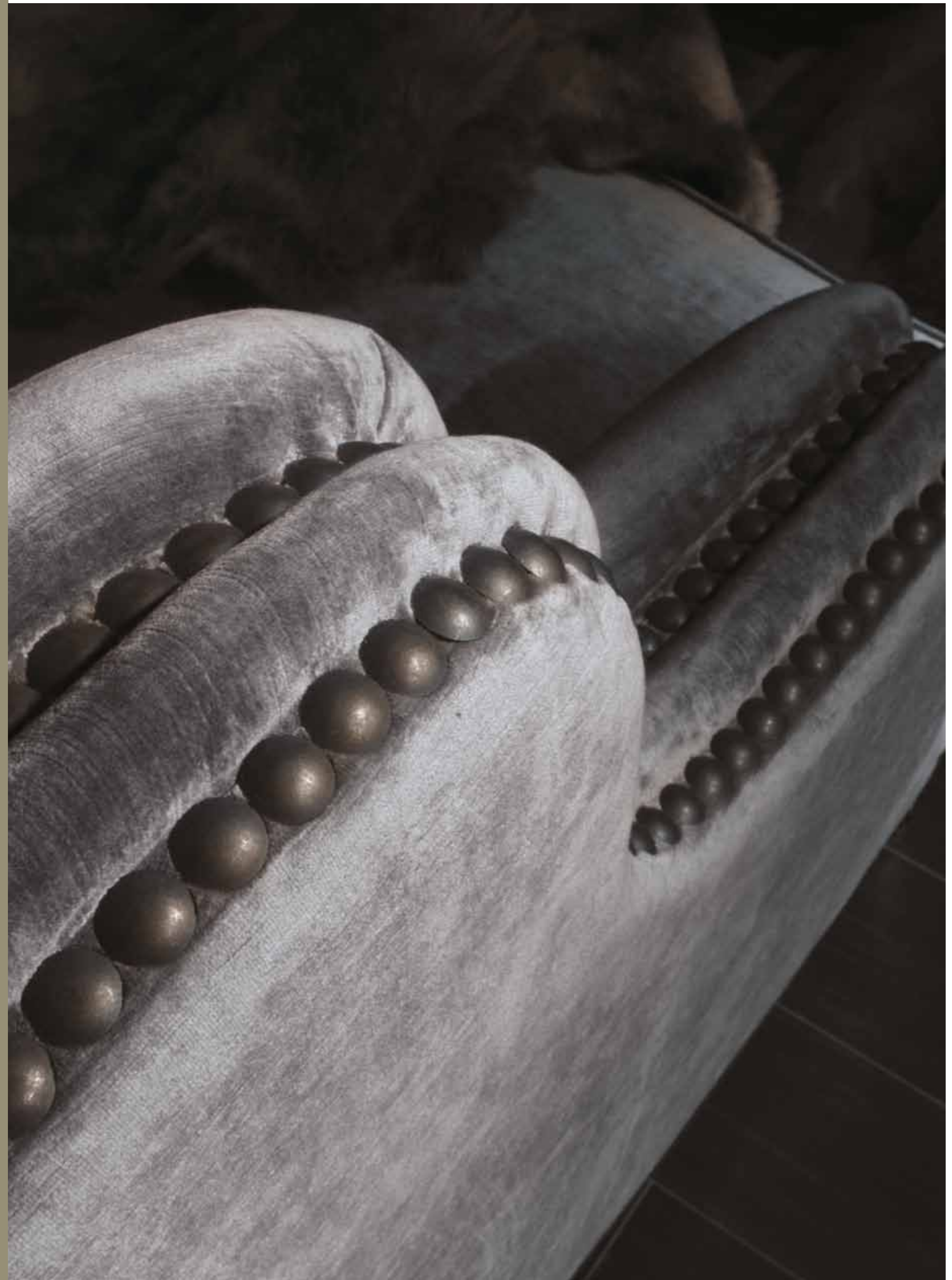







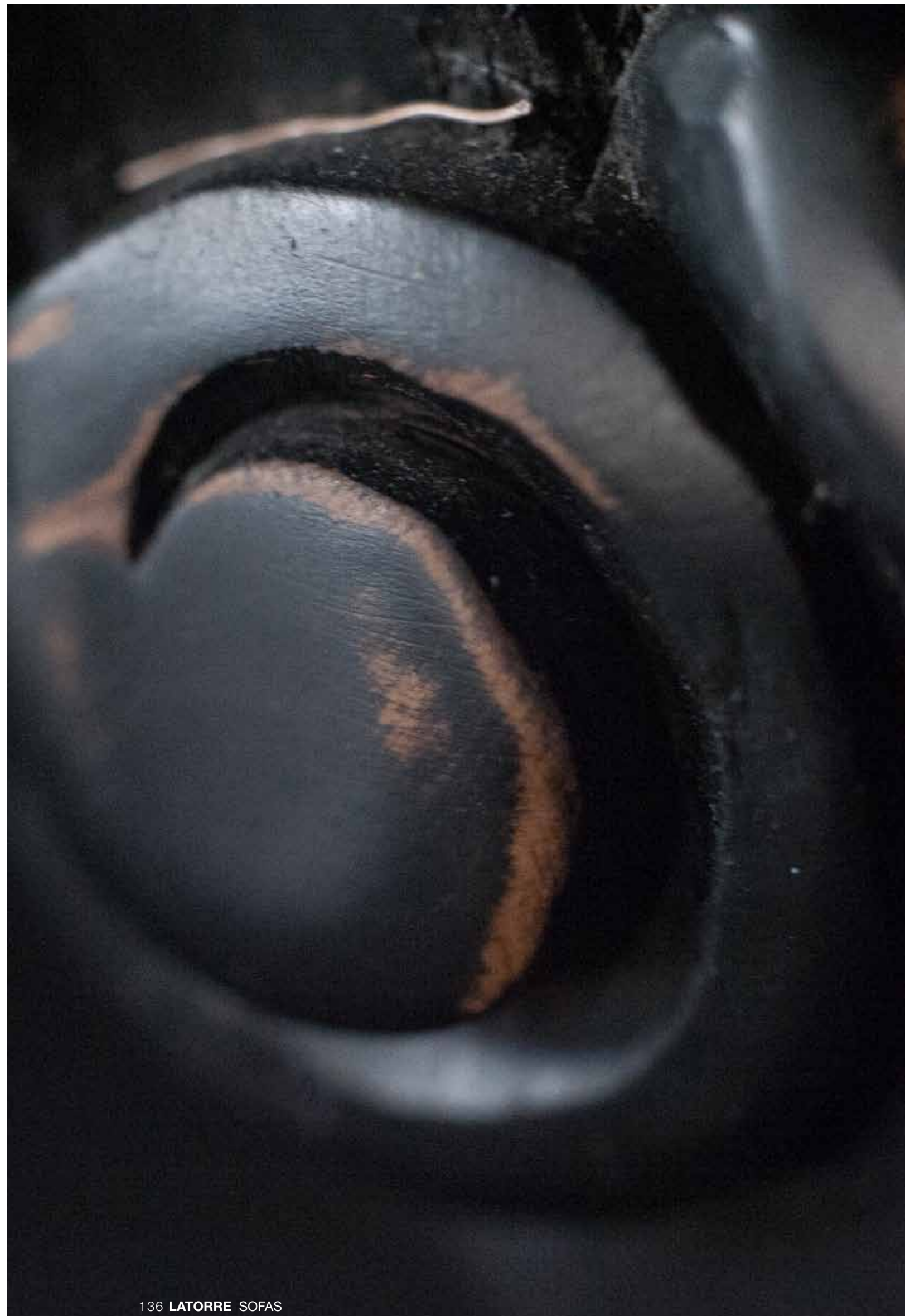











“Distancias,  
perspectivas y  
profundidades tapizadas  
de detalles únicos”

“Distances,  
perspectives and  
depths, filled with  
unique details”

CHAISE LONGUES

- 144 DIVA
- 150 LONG GROUND
- 152 FLANDES COUNTRY
- 154 MINI DIVAN

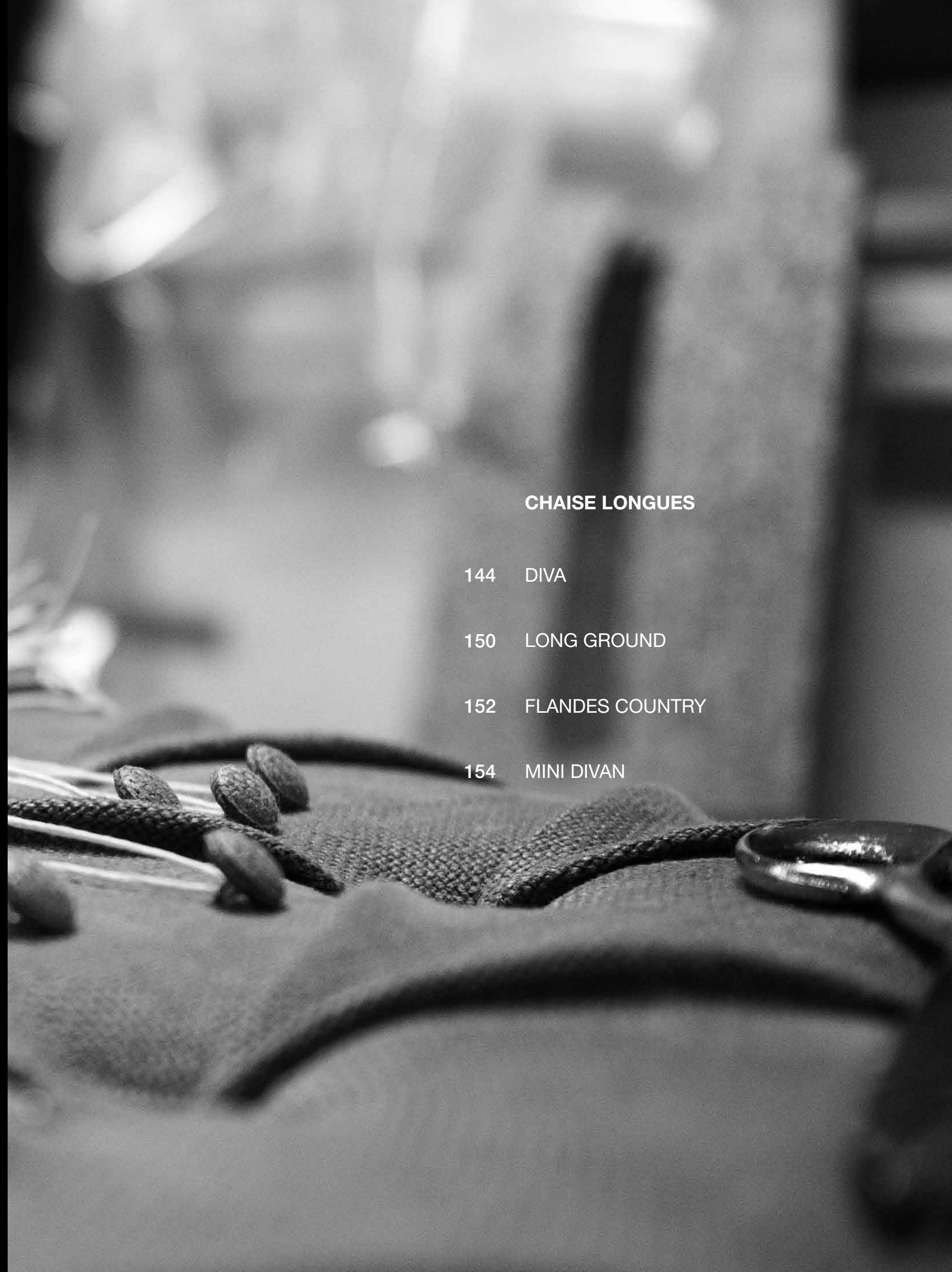



LATORRE COLLECTION

# DIVA

---

DESIGN GUILLERMO T

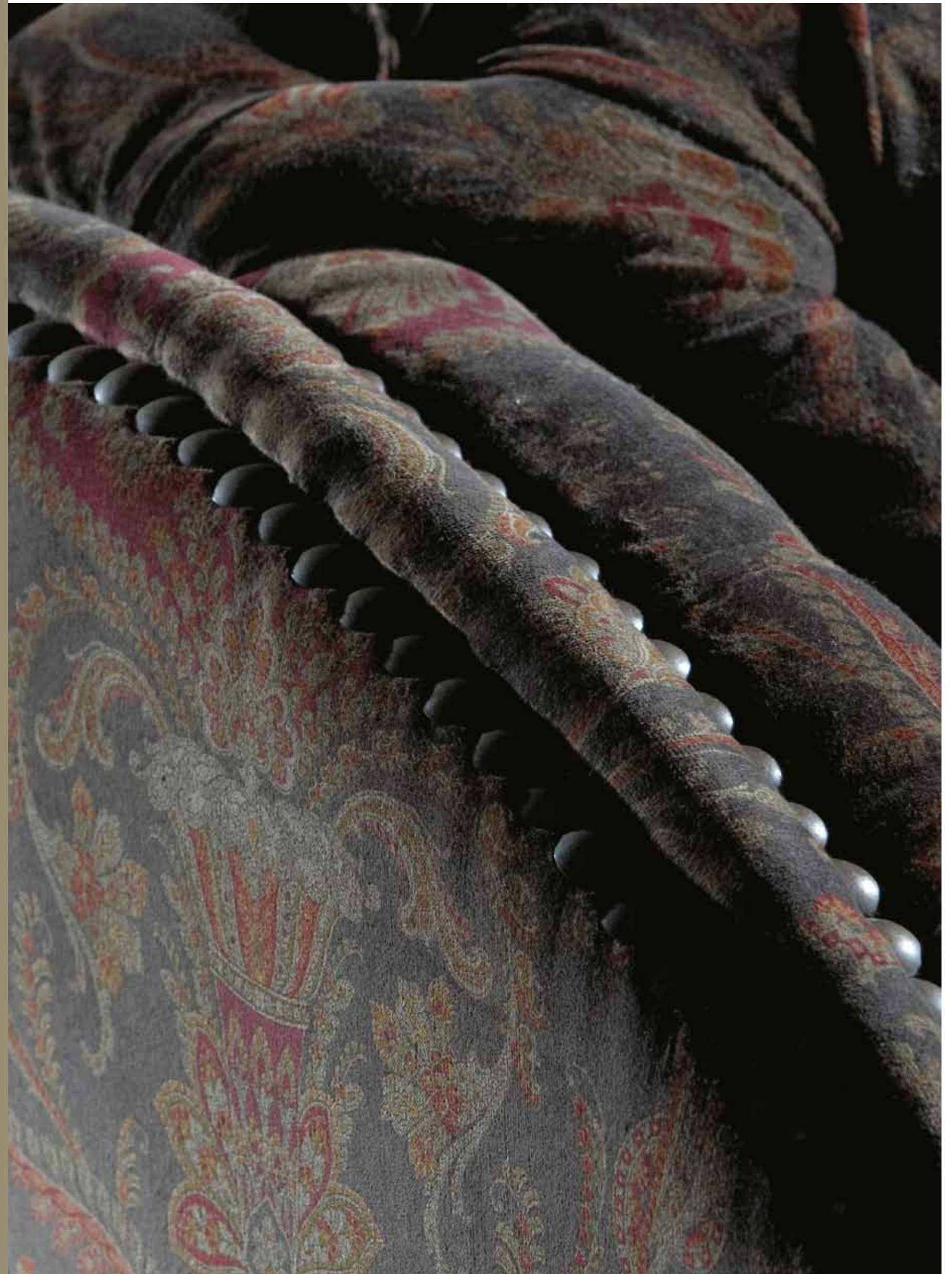











A black crocodile-patterned leather chaise longue is the central focus, positioned on a dark wooden floor. The room is dimly lit, with a large, ornate brass mirror in the background and a chandelier with blue and silver ornaments hanging from the ceiling. The chaise longue has a curved, ergonomic design with a high backrest and a footrest.

# LONG GROUND

DESIGN GUILLERMO T



LATORRE COLLECTION

# FLANDES COUNTRY

DESIGN GUILLERMO T

152 LATORRE CHAISE LONGUES

DECORATION Carlos Serra. Mercader de Indias, Valencia



FLANDES COUNTRY Chaise longue

LAND Low chair



LATORRE COLLECTION

## MINI DIVAN

---

LATORRE DESIGN DEPARTMENT



MINI DIVAN Chaise longue



“Con el romanticismo del  
producto hecho a mano”

“With the romance of  
a handmade product”

**WINGCHAIRS**

158 MONTGOMERY

162 GREENWICH

166 GEORGES

168 EARTH

172 MAXI TOMS COUNTRY

174 WALTER LOVE SEAT







**MONTGOMERY**

DESIGN GUILLERMO T







160 LATORRE WINGCHAIRS



MONTGOMERY COUNTRY Wingchair



LATORRE COLLECTION

## GREENWICH

DESIGN GUILLERMO T

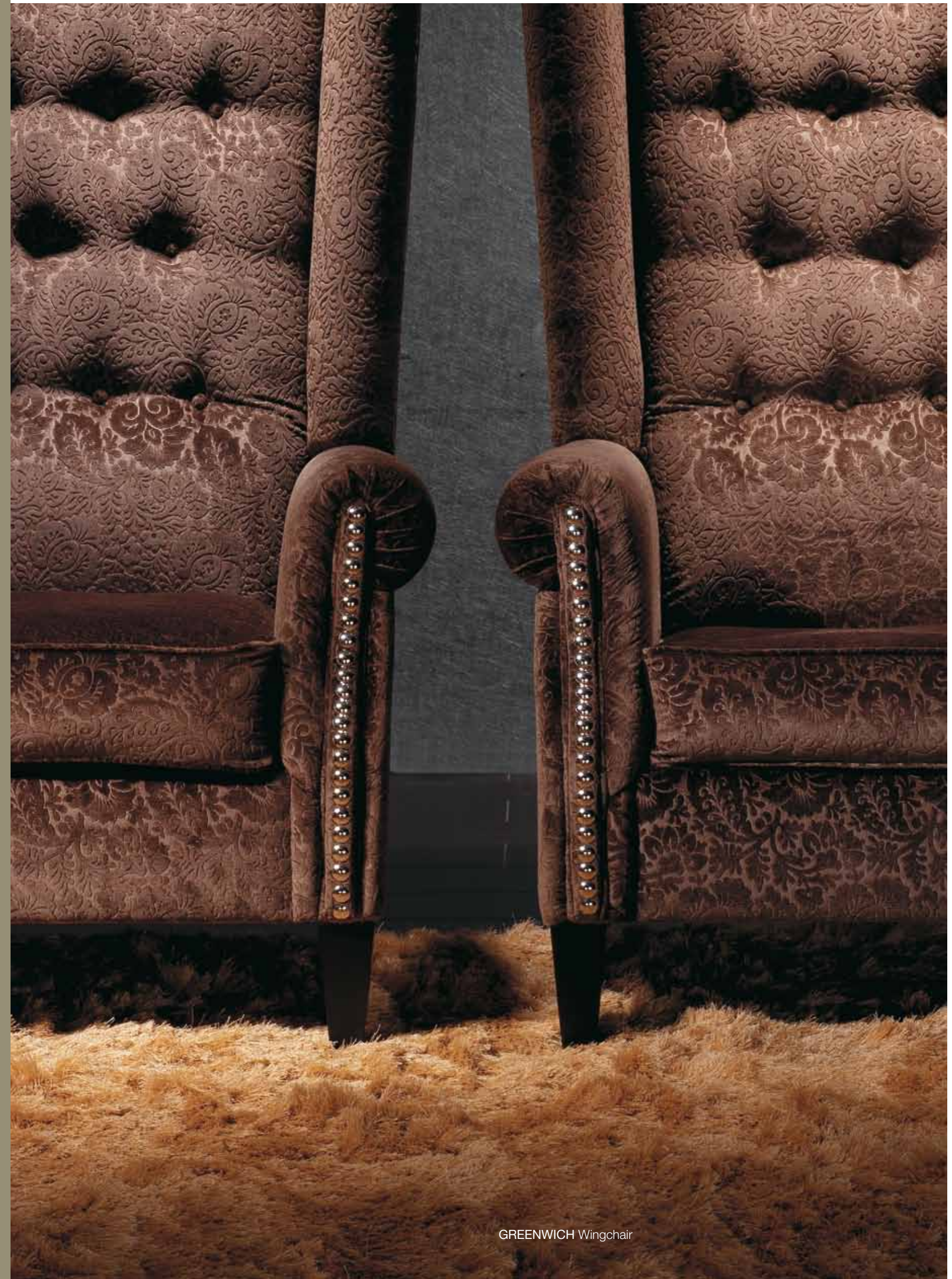

GREENWICH Wingchair





164 LATORRE WINGCHAIRS



GREENWICH Wingchair





# GEORGES

LATORRE DESIGN DEPARTMENT





LATORRE COLLECTION

## EARTH

---

DESIGN GUILLERMO T



EARTH Wingchair





170 LATORRE WINGCHAIRS



EARTH Wingchair





**MAXI TOMS COUNTRY**

DESIGN GUILLERMO T





**WALTER LOVE SEAT**

LATORRE GUILLERMO T





“El desafío: extraer la esencia del clásico para crear diseños de vanguardia”

“The challenge: to extract the essence of the classical to create avant-garde designs”

**ARMCHAIRS  
& EASY CHAIRS**

178 DELANOIS

182 ANDREW

186 LOW NIGHTINGALE

188 ODENSE

190 ÉLYSÉE

194 TRUMAN

196 BRIGHTON

198 LAND



LATORRE COLLECTION

## DELANOIS

DESIGN GUILLERMO T

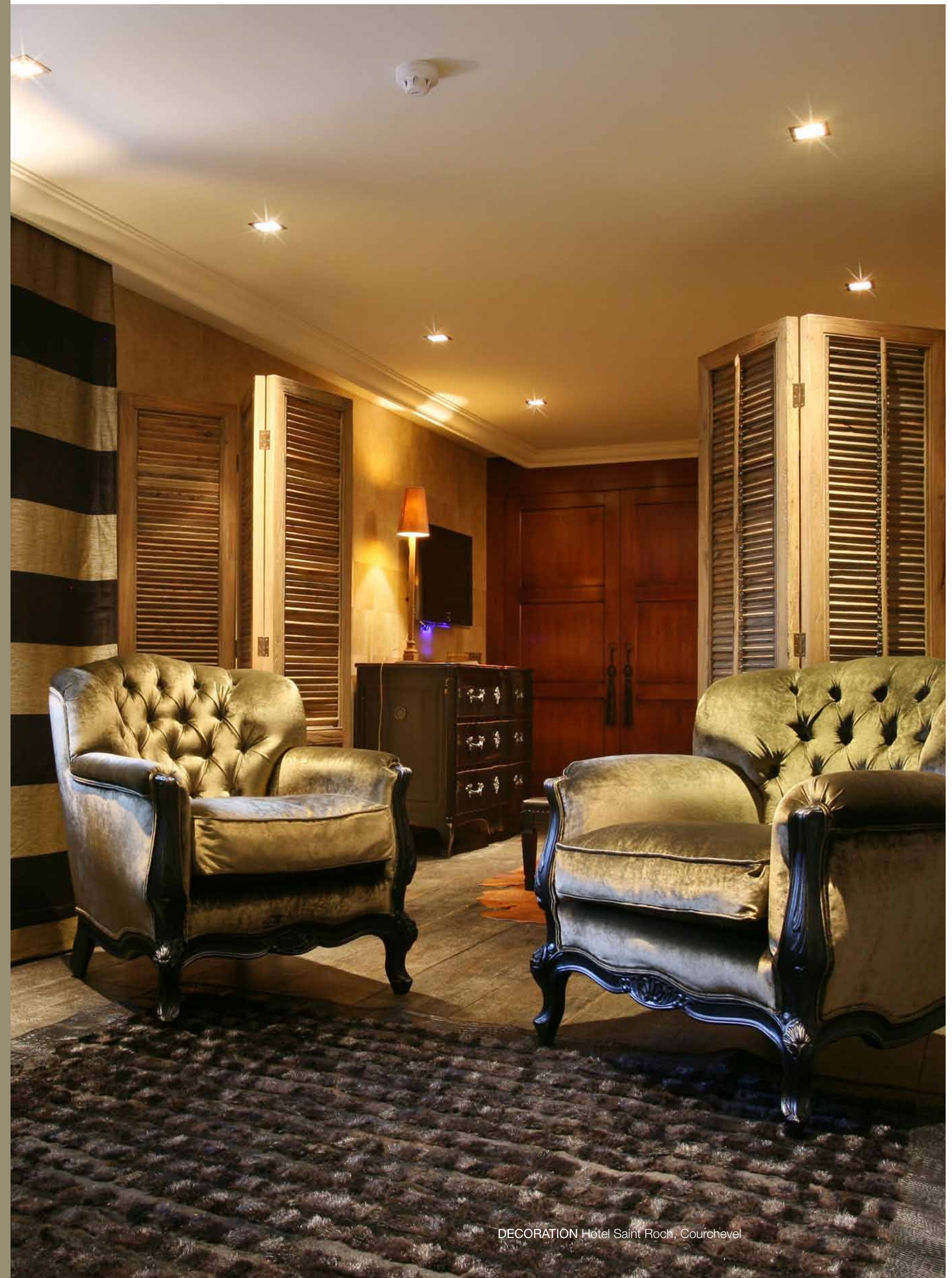







LATORRE COLLECTION

## ANDREW

---

LATORRE DESIGN DEPARTMENT











# LOW NIGHTINGALE

DESIGN CARLOS MAYORAL



LOW NIGHTINGALE Armchair

WYNDHAM Carpet

CASANDRA Floor & roof lamp





# ODENSE

DESIGN GUILLERMO T





# ÉLYSÉE

DESIGN GUILLERMO T









LATORRE COLLECTION

# TRUMAN

---

LATORRE DESIGN DEPARTMENT



TRUMAN Armchair



# BRIGHTON

LATORRE DESIGN DEPARTMENT



BRIGHTON Low chair



LATORRE COLLECTION

# LAND

DESIGN GUILLERMO T

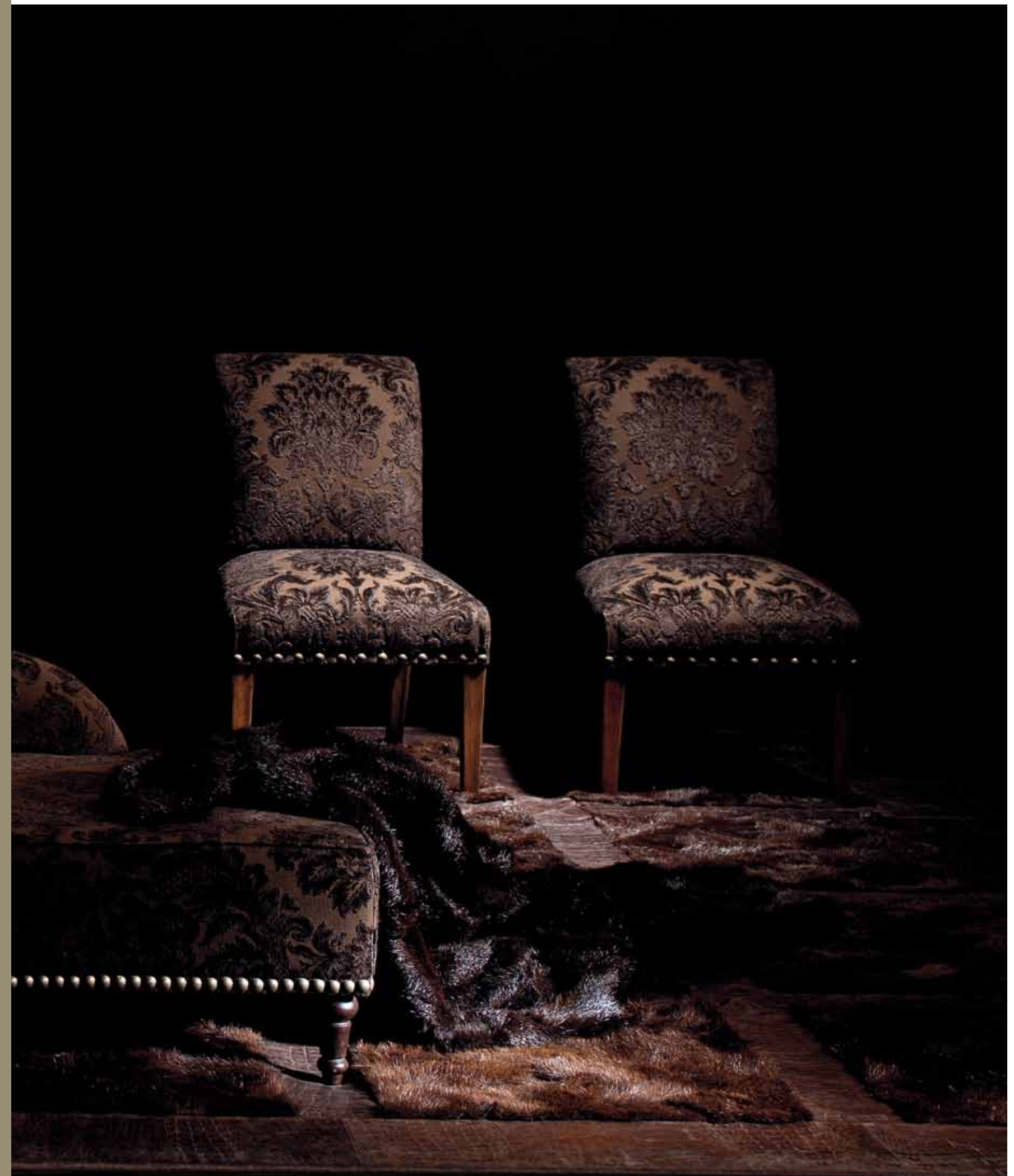

LAND Low chair



“Sello indiscutible  
del lujo y la calidad”  
“Unquestionable stamp  
of luxury and quality”

**COFFEE TABLES  
& STOOLS**

202 STAFFORD

204 KNIGHTSBRIDGE

206 AINSLEY

208 CHELSEA

212 DOLOMITA

214 MARMORE

216 VERMONT

218 CONCORDE

220 VENDÔME

224 CARONTE

226 CRUZADA COUNTRY







**STAFFORD**

DESIGN GUILLERMO T



CHARLES XXL Sofa

STAFFORD Coffee table



# KNIGHTSBRIDGE

DESIGN MARÍA JOSÉ GIMENO



KNIGHTSBRIDGE Coffee table

GRAND NATIONAL MODULAR Sofa



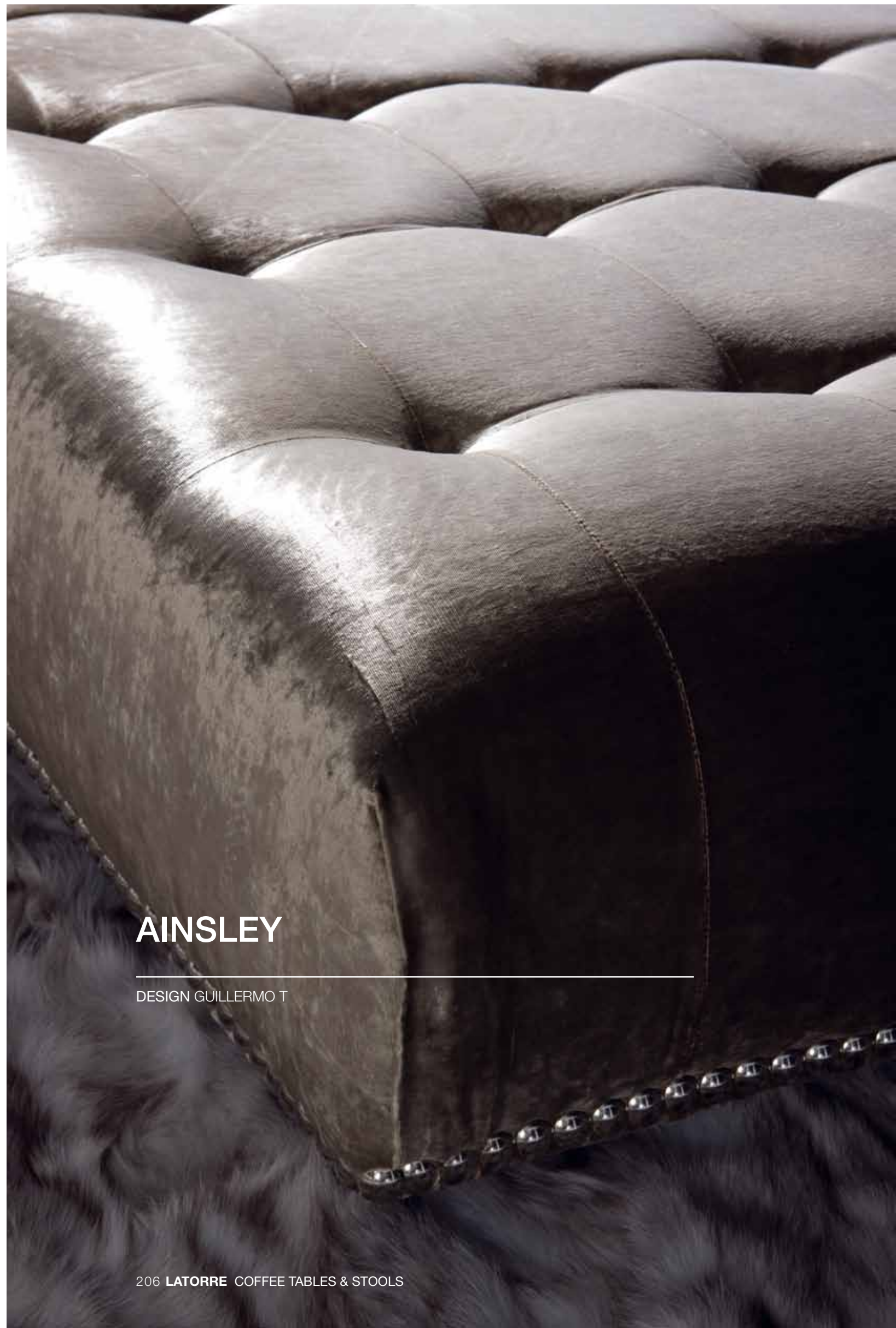

**AINSLEY**

DESIGN GUILLERMO T



AINSLEY Coffee table

BOND Sofa

GENTLEMAN WHITE Carpet



LATORRE COLLECTION

## CHELSEA

LATORRE DESIGN DEPARTMENT



CHELSEA Coffee table







LATORRE COLLECTION

## DOLOMITA

DESIGN MACALULA



DOLOMITA Coffee and side table

MAYFAIR Sofa

VENICE Table lamp

GENTLEMAN BLACK Carpet





**MARMORE**

DESIGN MACALULA



LATORRE COLLECTION

## VERMONT

LATORRE DESIGN DEPARTMENT



GRAND NATIONAL AUTOBIOGRAPHY Sofa

VERMONT Telescopic coffee table

GENTLEMAN WHITE Carpet



# CONCORDE

DESIGN GUILLERMO T

CONCORDE Coffee table

PRINCE Bookcase

GENTLEMAN WHITE Carpet



LATORRE COLLECTION

# VENDÔME

---

DESIGN GUILLERMO T

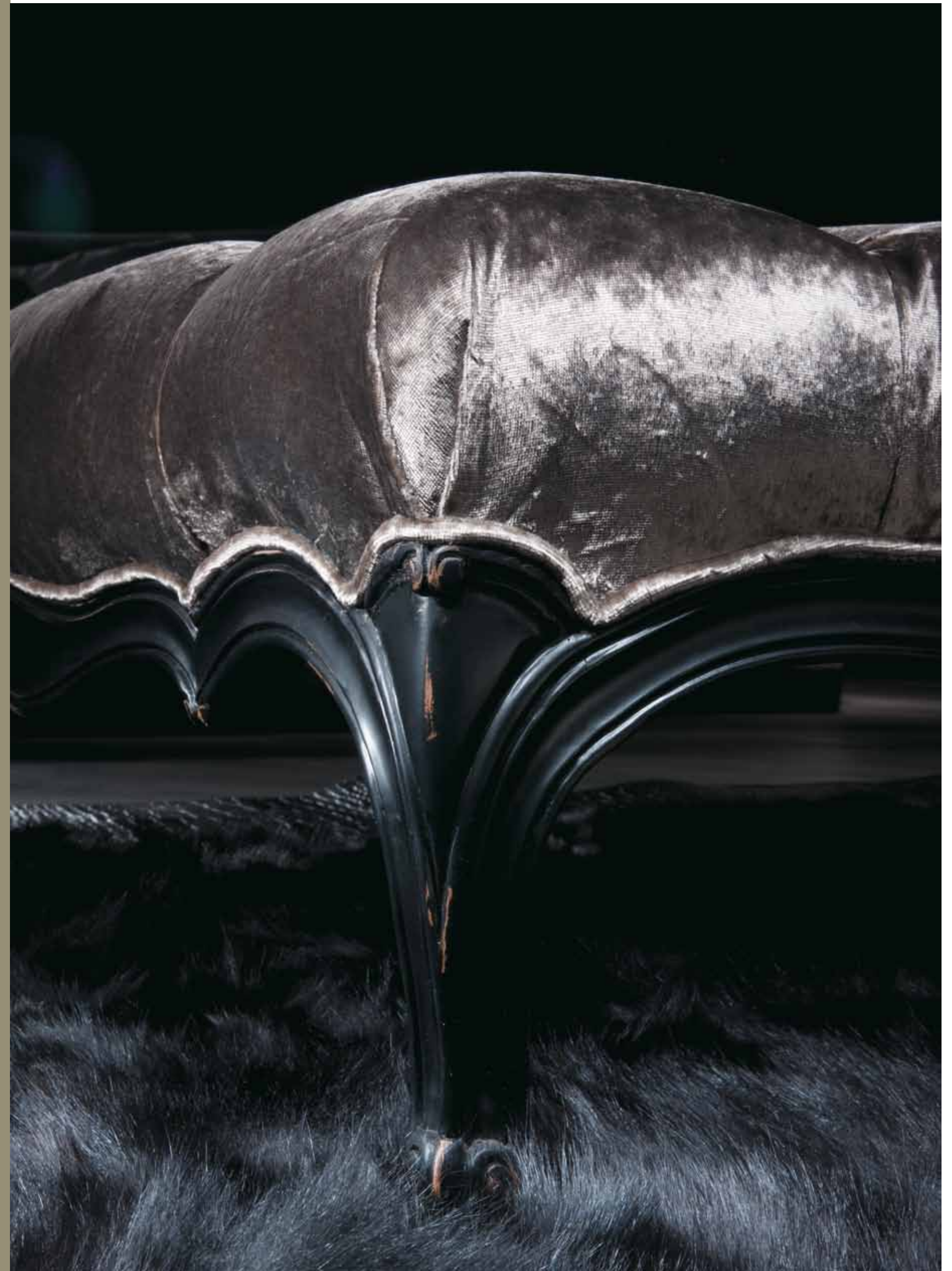









## CARONTE

DESIGN GUILLERMO T



CARONTE Stool

DANTE Sofa



# CRUZADA COUNTRY

LATORRE DESIGN DEPARTMENT





“Máxima representación del romanticismo de épocas pasadas con un toque actual”

“The epitome of a romantic bygone era yet have a contemporary twist”

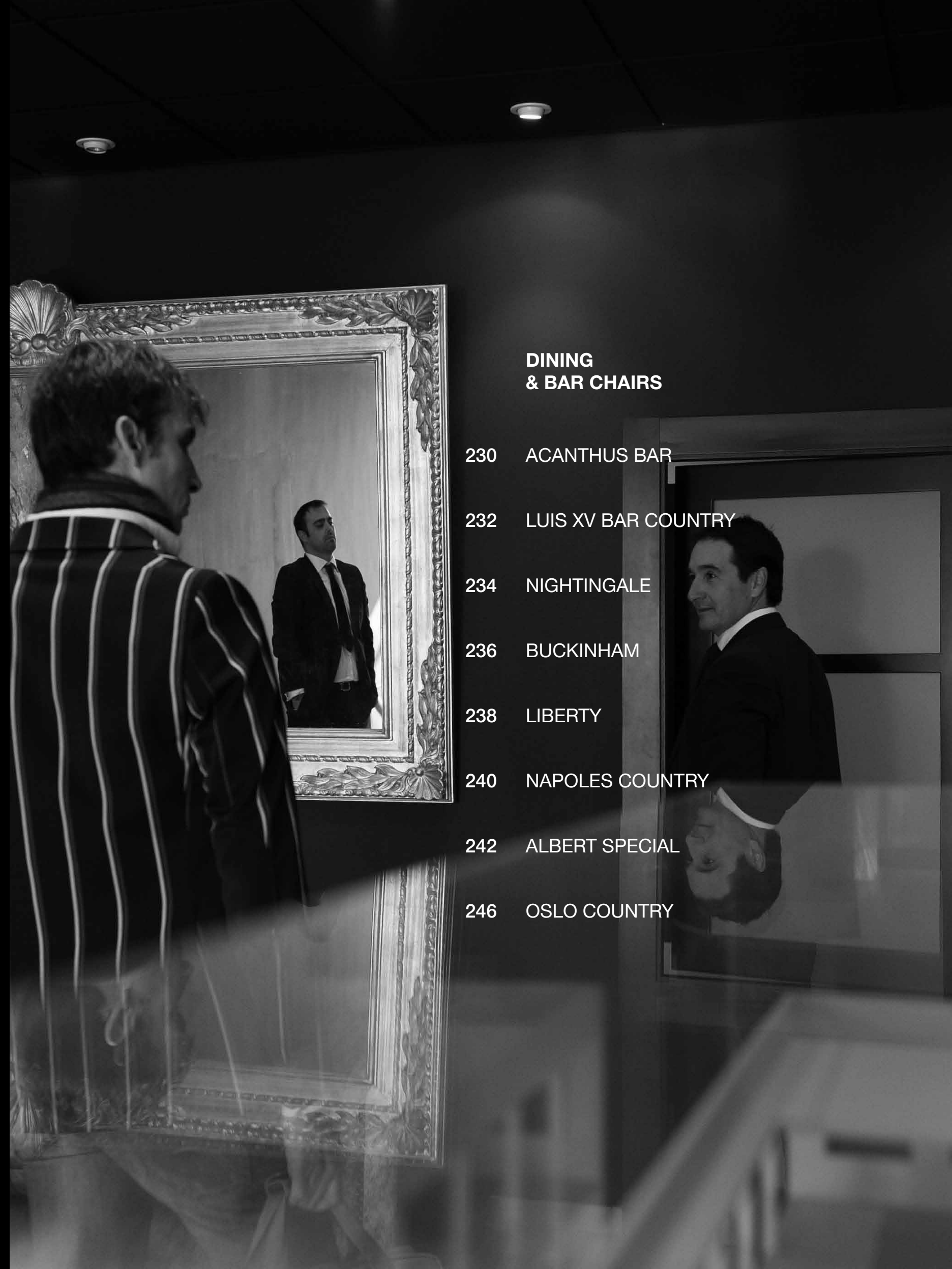

**DINING  
& BAR CHAIRS**

230 ACANTHUS BAR

232 LUIS XV BAR COUNTRY

234 NIGHTINGALE

236 BUCKINHAM

238 LIBERTY

240 NAPOLES COUNTRY

242 ALBERT SPECIAL

246 OSLO COUNTRY



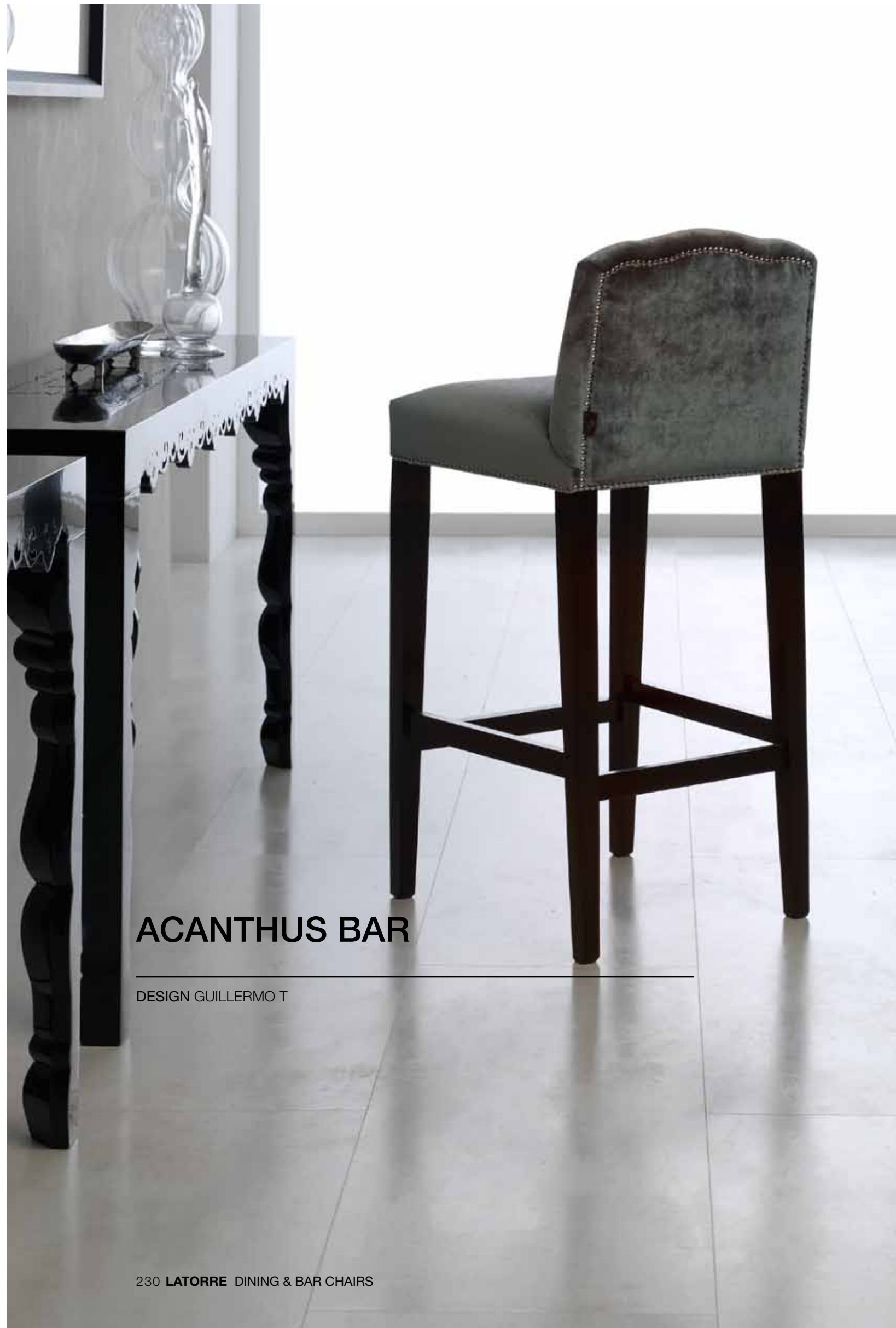

## ACANTHUS BAR

DESIGN GUILLERMO T



ACANTHUS BAR Chair

PROTOCOLLO Console



**LUIS XV BAR  
COUNTRY**

LATORRE DESIGN DEPARTMENT







# NIGHTINGALE

DESIGN CARLOS MAYORAL





LATORRE COLLECTION

## BUCKINGHAM

---

LATORRE DESIGN DEPARTMENT



BUCKINGHAM Chair



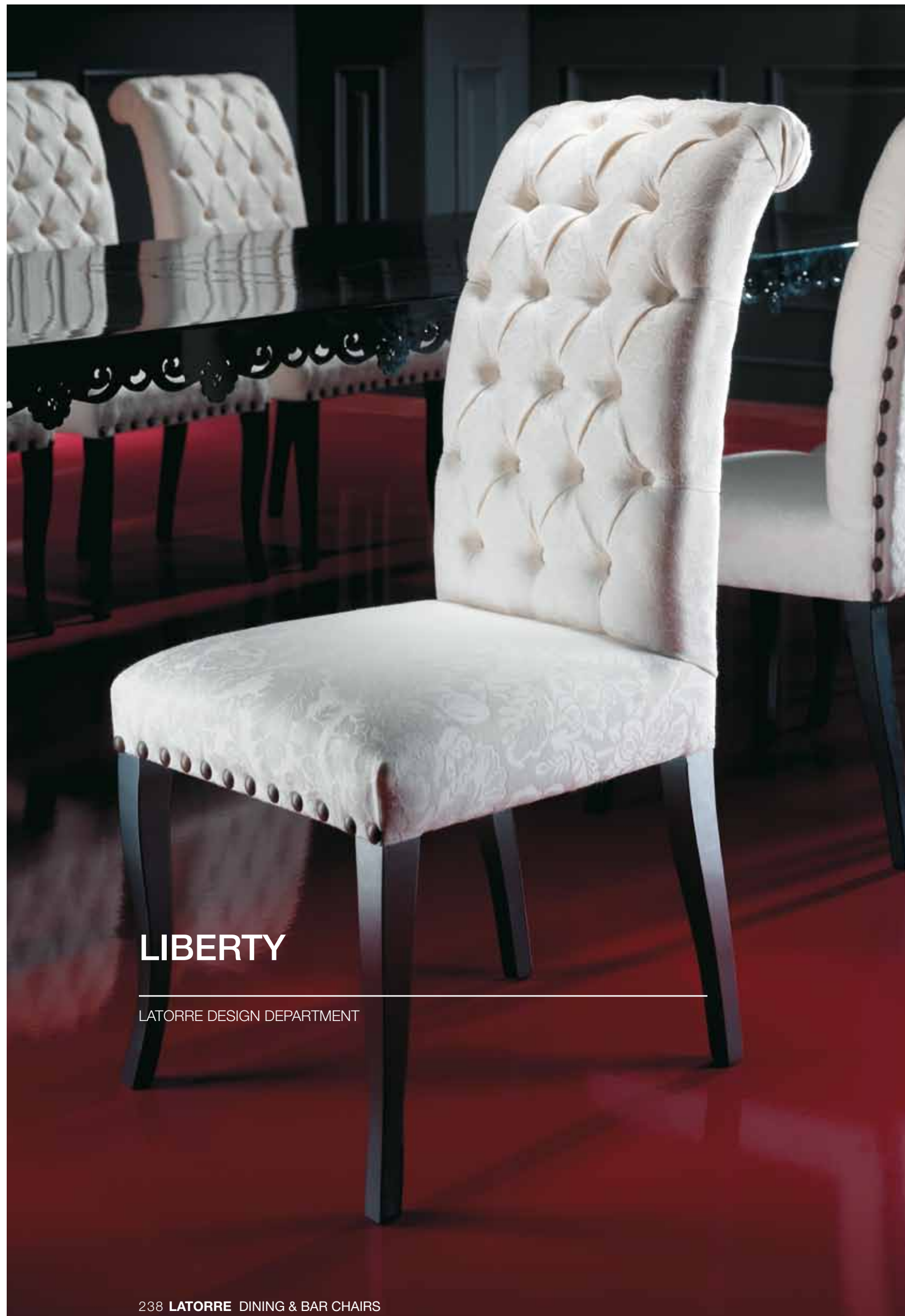

**LIBERTY**

LATORRE DESIGN DEPARTMENT



LIBERTY Chair

PROCOLO Table



LATORRE COLLECTION

## NAPLES COUNTRY

---

LATORRE DESIGN DEPARTMENT

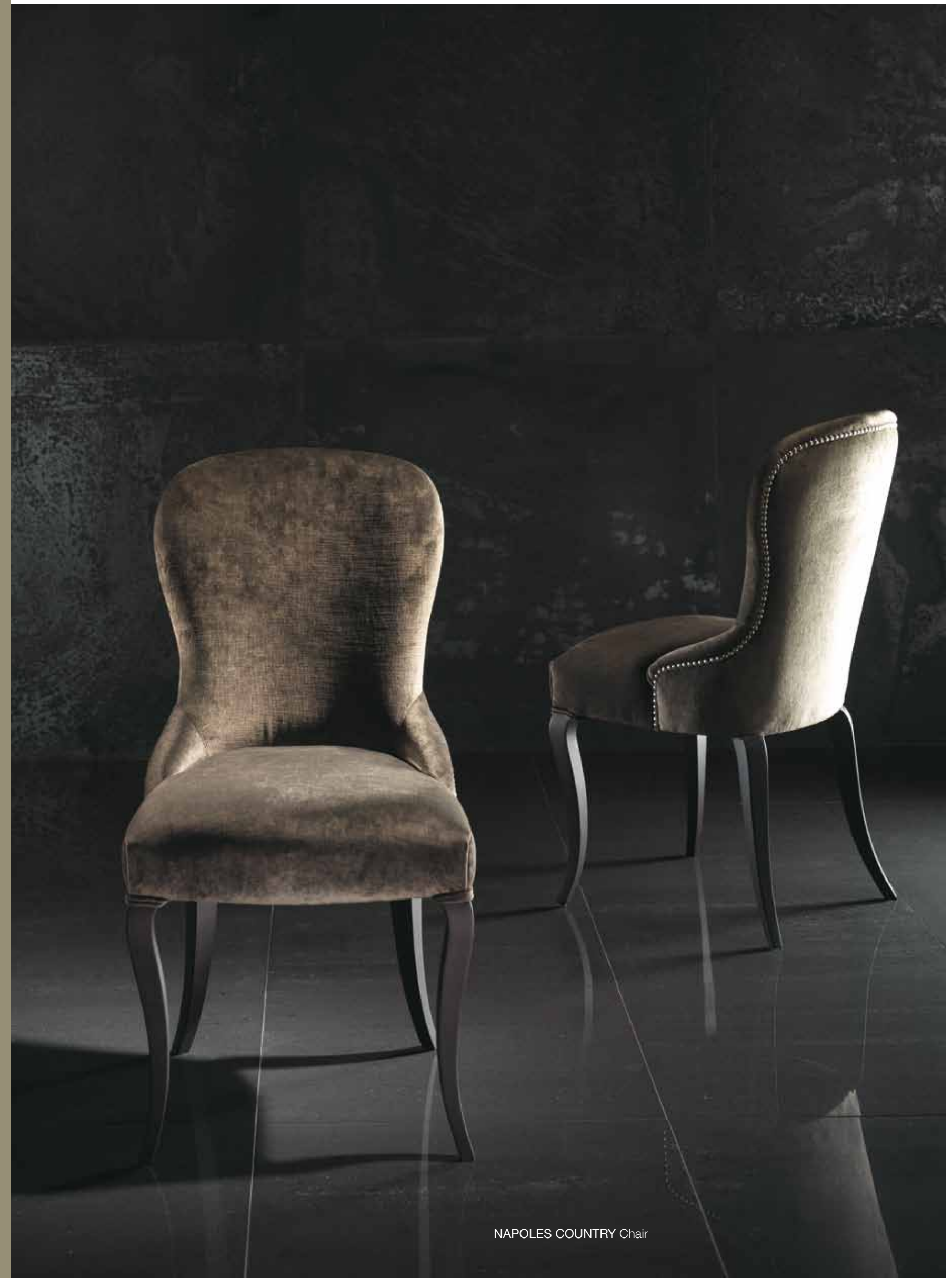

NAPLES COUNTRY Chair



LATORRE COLLECTION

## ALBERT SPECIAL

---

DESIGN GUILLERMO T



ALBERT SPECIAL Armchair





244 LATORRE DINNING & BAR CHAIRS

DECORATION Suzanne Loggere, Holland



ALBERT SPECIAL Armchair



LATORRE COLLECTION

## OSLO COUNTRY

---

DESIGN GUILLERMO T



OSLO COUNTRY Armchair





248 LATORRE DINNING & BAR CHAIRS



OSLO COUNTRY Chair



“Trabajo minucioso  
y artesanal, único,  
de pureza estética”

“Unique, meticulous  
craftsmanship with an  
immaculate appearance”



**TABLES**

252 GOLDENEYE

254 HEATHROW

258 PROCOLO





# GOLDENEYE

DESIGN MARÍA JOSÉ GIMENO



GOLDENEYE Table

NIGHTINGALE Chair



# HEATHROW

DESIGN GUILLERMO T

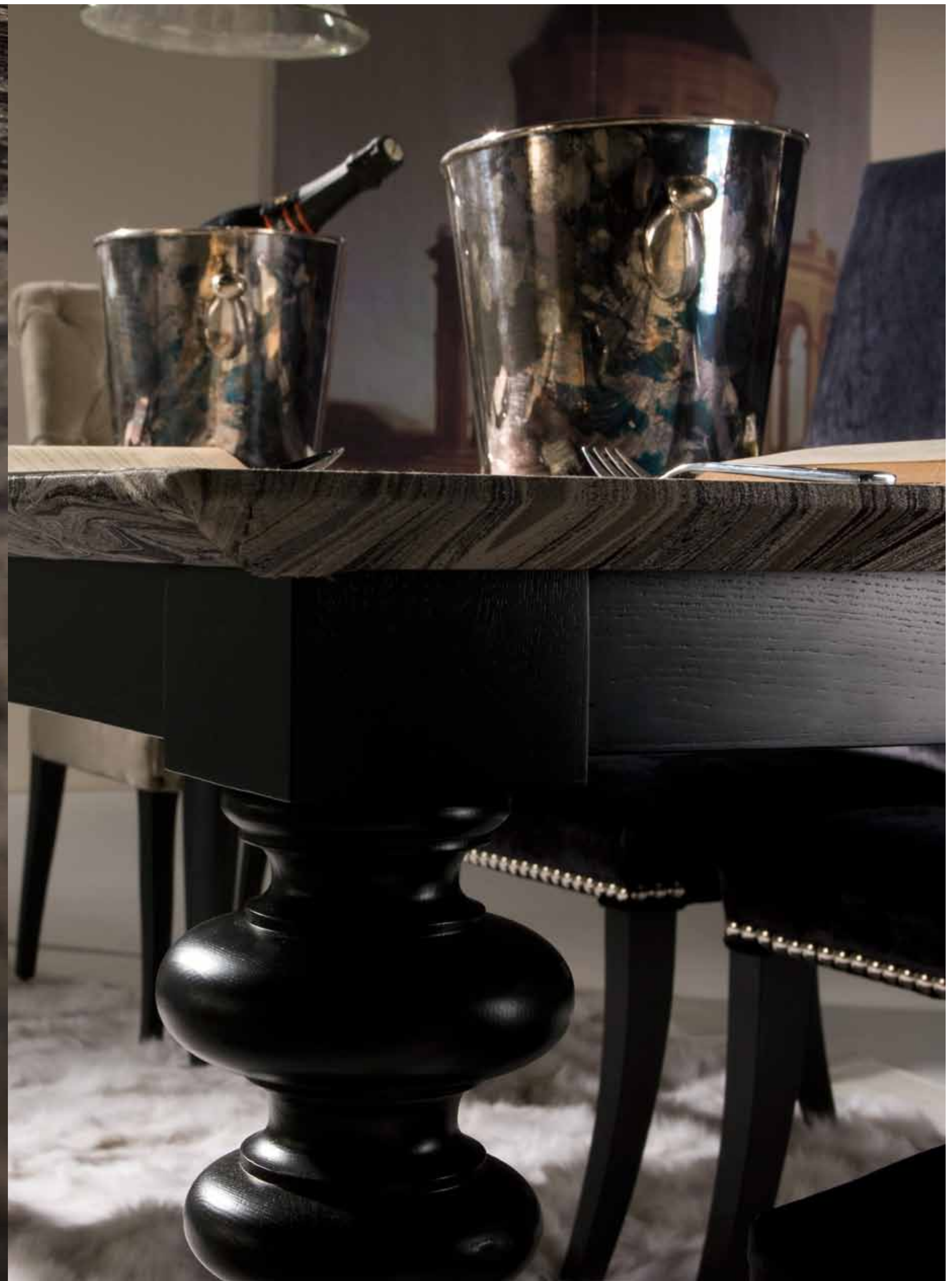





HEATHROW Table

LIBERTY Chair

BUCKINGHAM Chair

FLOFÀ Armchair

ETNA Lamp

MR. BOJANGLES Mirror

GENTLEMAN WHITE Carpet





# PROCOLO

DESIGN MACALULA









“Identidad de  
una empresa que  
crece sin parar”  
“The identity of a  
company that is  
constantly growing”



264 PRINCE BOOKCASE

266 LAUREN BED





PRINCE

DESIGN GUILLERMO T





# LAUREN

DESIGN GUILLERMO T

266 LATORRE BED

LAUREN Bed

MARMORE Side table

VENICE Table lamp

GENTLEMAN BLACK Carpet

DARK Plaid



“Búsqueda constante de la belleza, con elegancia y buen gusto”

“A constant search for beauty, with elegance and exquisite taste”

MIRRORS

270 ALAIN

272 MR. BOJANGLES

274 MISS JONES

CARPETS

276 GENTLEMAN

280 WYNDHAM

LIGHTING

282 CASANDRA

286 ETNA

288 VENICE

294 PLAIDS

296 CUSHIONS





# ALAIN

DESIGN GUILLERMO T



ALAIN Mirror

ASCOT MODULAR Sofa



# MR. BOJANGLES

DESIGN GUILLERMO T



The image features three identical, ornate mirror frames arranged horizontally against a dark background. Each frame is composed of multiple concentric rectangular layers, creating a rich, textured appearance. The frames are illuminated from the side, highlighting their depth and the metallic sheen of the material. The central frame is slightly offset from the two flanking ones, creating a sense of depth and perspective.

# MISS JONES

---

DESIGN GUILLERMO T





## GENTLEMAN

LATORRE DESIGN DEPARTMENT



CHARLES Sofa

VENDÔME Coffee table

GENTLEMAN BLACK Carpet





CONCORDE Coffee table

GENTLEMAN WHITE Carpet



# WYNDHAM

DESIGN GUILLERMO T



LOW NIGHTINGALE Armchair

WYNDHAM Carpet



# CASANDRA

DESIGN QMD



CASANDRA Large roof lamp





CASANDRA Medium roof & floor lamp

LOW NIGHTINGALE Armchair

WYNDHAM Carpet



# ETNA

LATORRE DESIGN DEPARTMENT



ETNA Lamp



# VENICE

---

LATORRE DESIGN DEPARTMENT

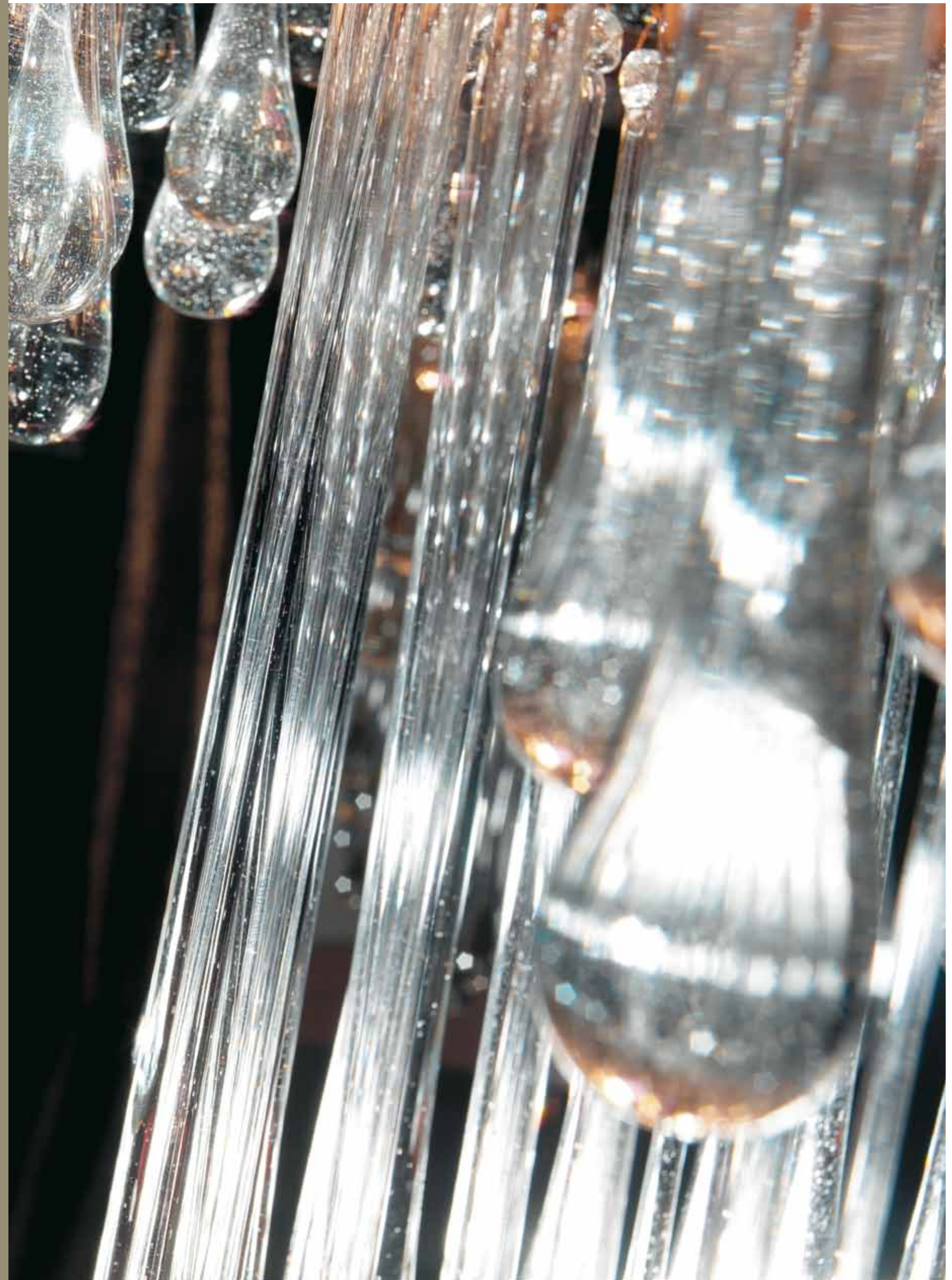





290 LATORRE LIGHTING



VENICE Roof & floor lamp  
PROTOCOLO Table  
LIBERTY Chair









# PLAIDS

LATORRE DESIGN DEPARTMENT

Black plaid & fur cushion



White plaid & fur cushion



Dark plaid & fur cushion



Pale plaid & fur cushion



Zebra rabbit plaid & fur cushion



Linx rabbit plaid & fur cushion



# CUSHIONS

LATORRE DESIGN DEPARTMENT



Box cushion



Rectangular box cushion

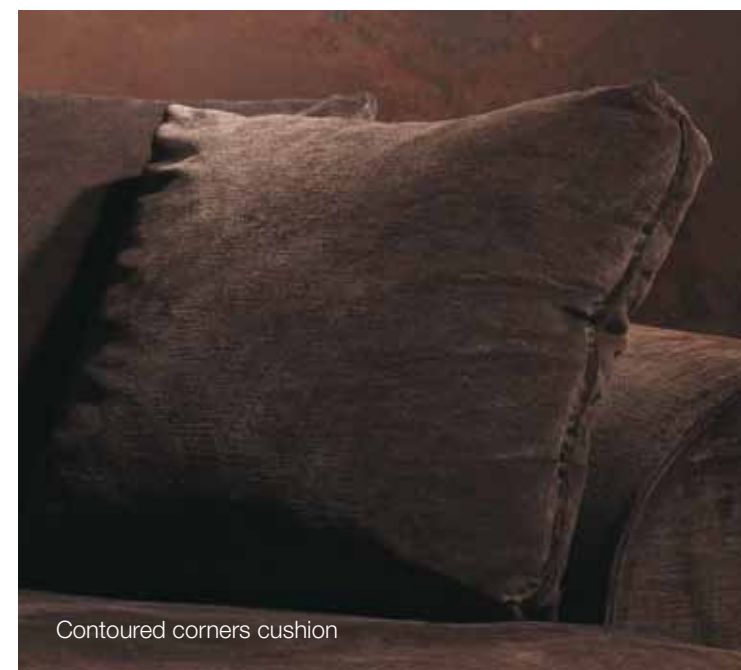

Contoured corners cushion



Rectangular contoured corners cushion

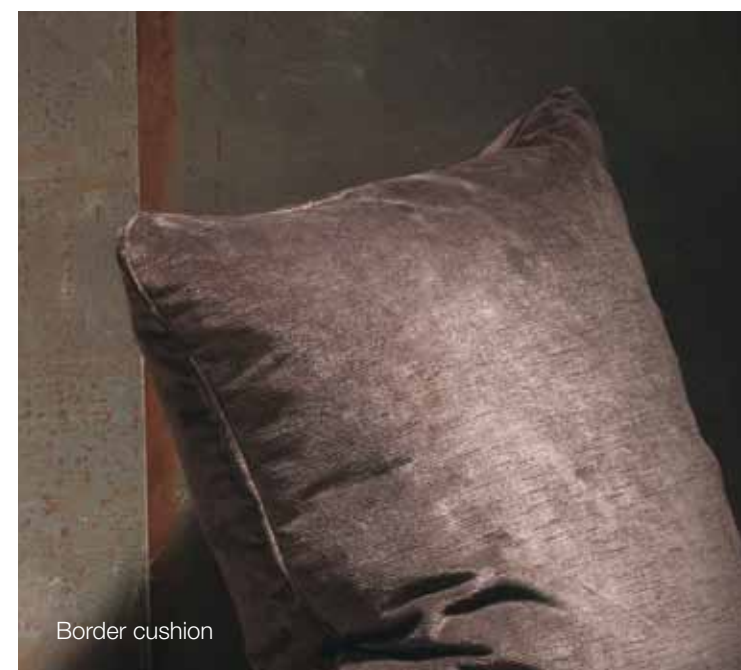

Border cushion



Rectangular border cushion





#### Agradecimientos:

A nuestros padres, Ascensión y Guillermo, por su formidable herencia: nuestros valores y nuestra educación. Sin los cuales no nos hubiera sido posible llevar a cabo tamaña empresa y la superación de los retos que seguimos marcándonos día a día.

A Angel Carbellido por su fidelidad y por su magnífico trabajo a lo largo de casi toda una vida.

A todo el equipo de Latorre, desde el personal de administración hasta los artesanos, que trabajan en nuestros diferentes departamentos, pasando por los encargados, agentes comerciales y distribuidores. A Mariangeles, Maribel, Cruz, Svetlana, Daniela, Diego, Toni, Oscar, Luis, Paco, María José y a Mr. Trigo. A nuestros deportistas de élite, que llevan los colores de Latorre, entre ellos y especialmente al jinete J. Ignacio Jiménez-Rico. A Carmen Martínez, Rosa Roca, Cristina Jiménez, Eva Goig, Miquel Torrent, Horacio Silva, Olesya Bezuglaya, Marisol Sánchez, Jessica Patay, Pedro Llorca, Dolors Serra, Juan Carlos Vega, Nacho Pérez, Alberto Argüelles, y Rafael Soriano porque, sin ellos, este catálogo no tendría el sentido que tiene.

A toda la familia.

A Ximo Roca por su entusiasmo, ayuda incondicional y sabiduría al saber transmitir la singularidad de todas nuestras piezas sin escatimar esfuerzos.

#### Acknowledgements:

To our parents, Ascensión and Guillermo, for their formidable legacy: our values and education. Without them it would not have been possible to build such a large enterprise or overcome the challenges that we set ourselves every day.

To Angel Carbellido, our own personal MacGyver, for his loyalty and commitment, someone who is never beaten by a problem.

To the entire Latorre team, the administrative staff and craftspeople working in our various departments as well as our foremen, sales agents and distributors. To Mariangeles, Maribel, Cruz, Svetlana, Daniela, Diego, Toni, Oscar, Luis, Paco, María José and Mr. Trigo. To our elite athletes who bear the Latorre colours, including and in particular the rider J. Ignacio Jiménez. To Carmen Martínez, Rosa Roca, Cristina Jiménez, Eva Goig, Miquel Torrent, Horacio Silva, Olesya Bezuglaya, Marisol Sánchez, Jessica Patay, Pedro Llorca, Dolors Serra, Juan Carlos Vega, Nacho Pérez, Alberto Argüelles and Rafael Soriano, without whom this catalogue would never have seen the light of day.

To the whole family.

To Ximo Roca for his enthusiasm, unconditional support and wisdom in sparing no effort to convey the uniqueness of all our items.



ASCENSIÓN LATORRE, S.L.

ALBACETE 4, POL. IND. BARRIO DE LOS DOLORES  
46113 MONTCADA, VALENCIA - SPAIN  
TEL. +34 96 139 50 32  
FAX +34 96 139 50 11  
www.ascensionlаторre.com  
www.paudesign.com



COLLABORATING FIRM:



DISEÑO GRÁFICO XIMO ROCA DISEÑO  
DIRECCIÓN ARTE Guillermo T  
FOTOGRAFÍA CLAUDIO INDIAS, MASFLASH, PEDRO LLORCA, CARLOS GUTIERREZ, DOLORS SERRA, NACHO PÉREZ  
IMPRIME KOLOR LITÓGRAFOS, S.L.

DEPÓSITO LEGAL: V-1550-2009.

COPYRIGHT © ASCENSIÓN LATORRE S.L. TODOS LOS DERECHOS RESERVADOS. ESTE CATÁLOGO SE HA PUBLICADO CON LA COLABORACIÓN DE LA CONSELLERIA D'INDÚSTRIA, COMERÇ I INNOVACIÓ DE LA GENERALITAT VALENCIANA.

## LATORRE TECHNICAL INFORMATION





LATORRE TECHNICAL INFORMATION

SOFAS

GRAND NATIONAL

design Latorre Design Department

pag: 008-021 / 205 / 217

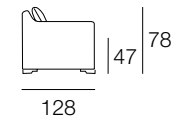

SOFA 7 ST.

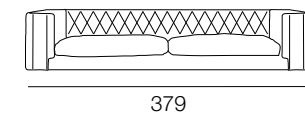

SOFA 5,5 ST.

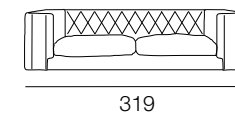

ARMCHAIR

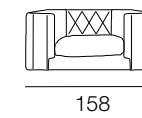

MODULE 7 ST. RIGHT ARM

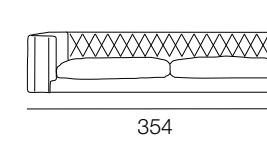

MODULE 5,5 ST. RIGHT ARM

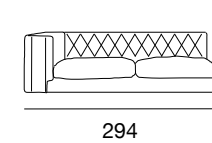

CHAISE LONGUE RIGHT ARM

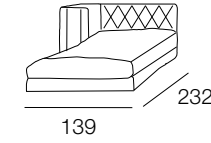

MODULE 7 ST. LEFT ARM

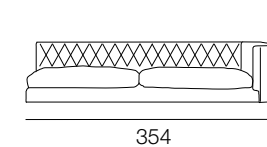

MODULE 5,5 ST. LEFT ARM

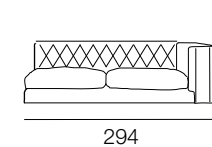

CHAISE LONGUE LEFT ARM

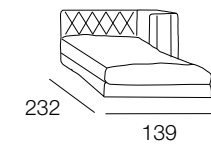

EXAMPLES:

SOFA 7 ST. & CH. L.

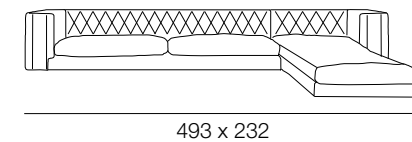

SOFA 5,5 ST. & CH. L.

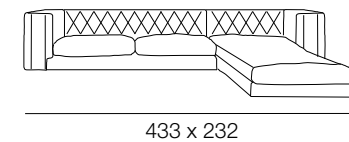

CHUKKA

design Rolf Zimmermann

pag: 038-049

EASY MOD.

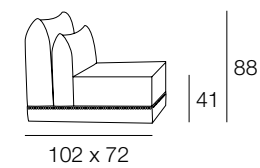

CORNER MOD.

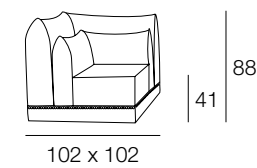

FOOTSTOOL

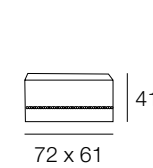

ARM CUSHION



H14 W37 D102

ARM STOOL

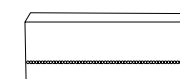

H41 W37 D102

PET TRAY

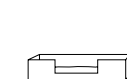

H14 W70 D60

SMALL TRAY



H7 W35 D60

MAYFAIR

design Guillermo T

pag: 022-037 / 213 / 214

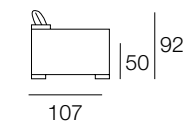

SOFA 4 ST.

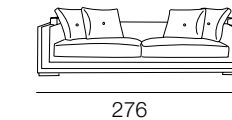

SOFA 3 ST.

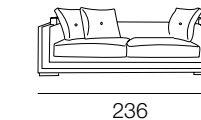

ARMCHAIR

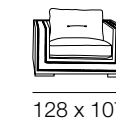

STOOL

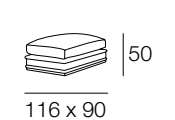

MODULE 4 ST. RIGHT ARM

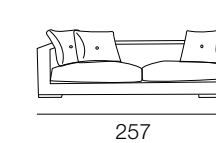

MODULE 3 ST. RIGHT ARM

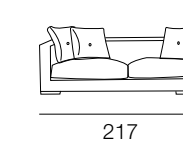

CHAISE LONGUE RIGHT ARM

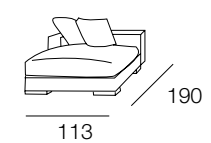

MODULE 4 ST. LEFT ARM

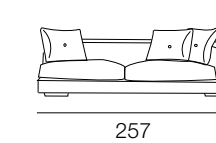

MODULE 3 ST. LEFT ARM

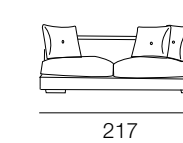

CHAISE LONGUE LEFT ARM

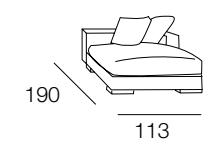

EXAMPLES:

MODULE 4 ST. & CHAISE LONGUE

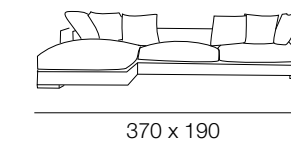

MODULE 3 ST. & CHAISE LONGUE

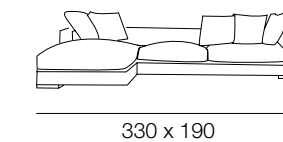

ROYALTON

design Guillermo T

pag: 062-073

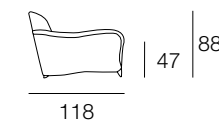

SOFA 5 ST.

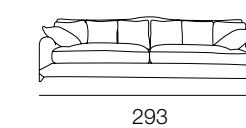

SOFA 3,5 ST.

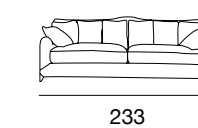

DANTE

design Guillermo T

pag: 110-117

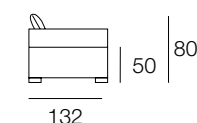

SOFA 6 ST.

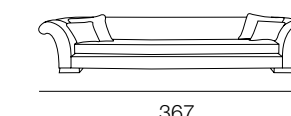

SOFA 4,5 ST.

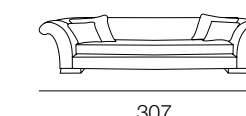

SOFA 3 ST.

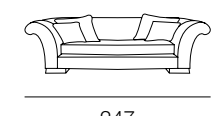





LATORRE TECHNICAL INFORMATION

SOFAS

ASCOT  
design Guillermo T

pag: 50-57 / 272

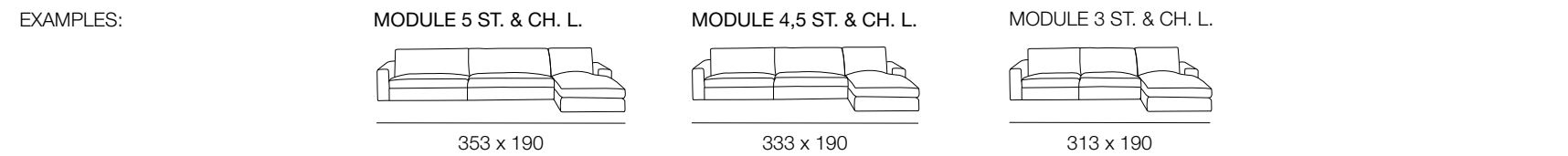
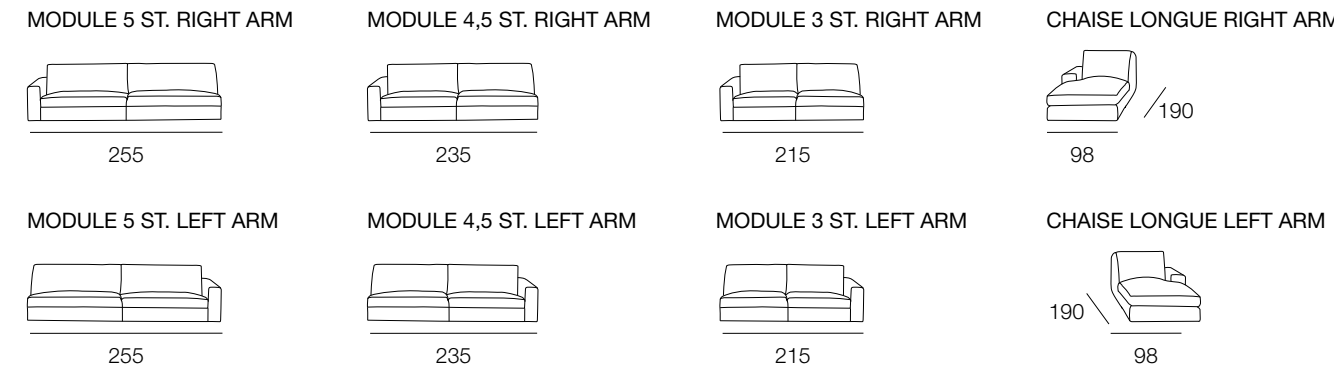
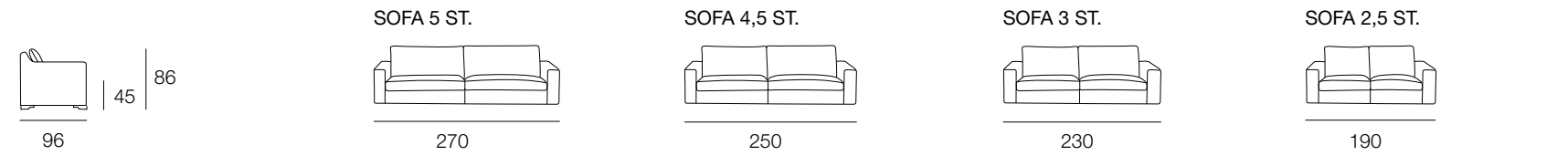

FLOFÀ  
design Cristina Gorzanelli

pag: 074-087 / 136 / 256

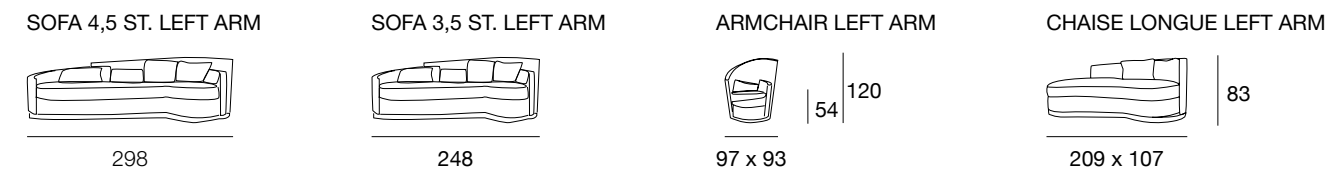
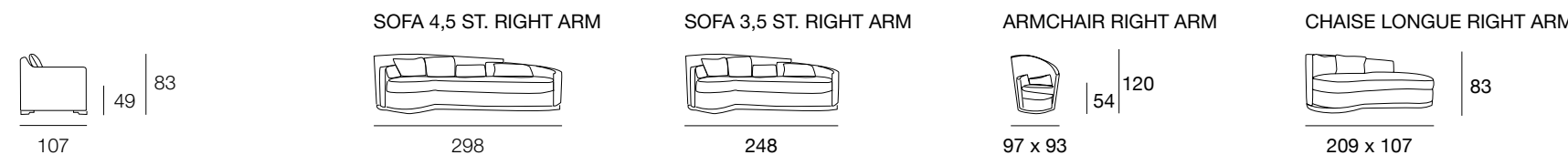

CHARLES  
design Guillermo T

pag: 100-109 / 202 / 222 / 278



BOND  
design Guillermo T

pag: 058-061 / 206

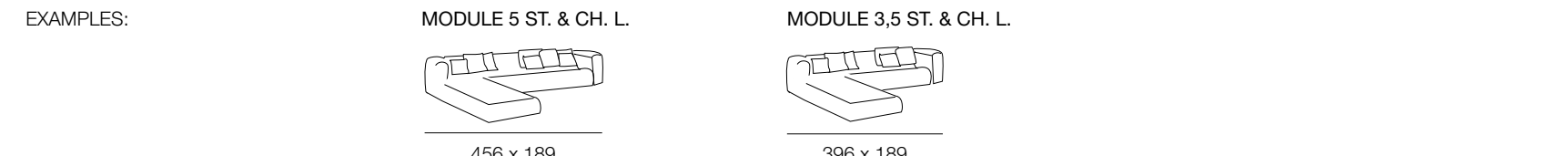
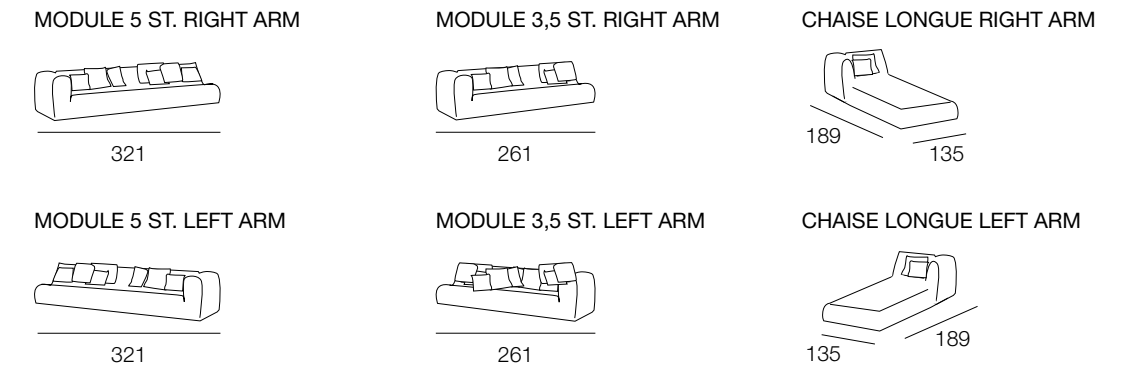
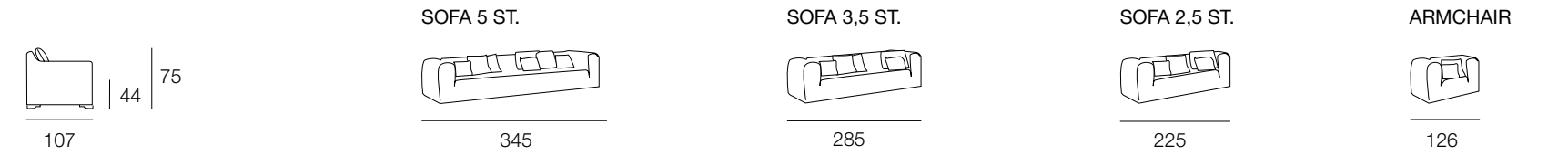

CHARLES XXL  
design Guillermo T

pag: 088-099

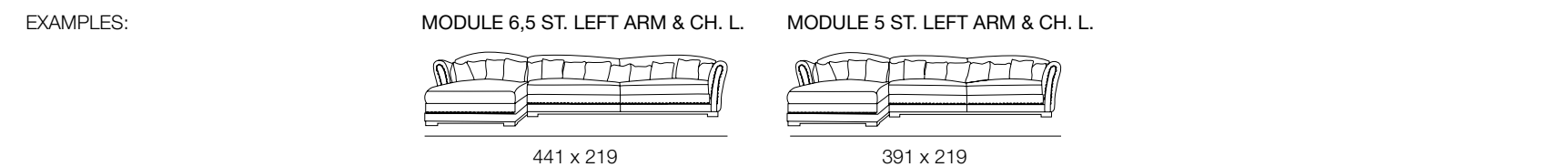
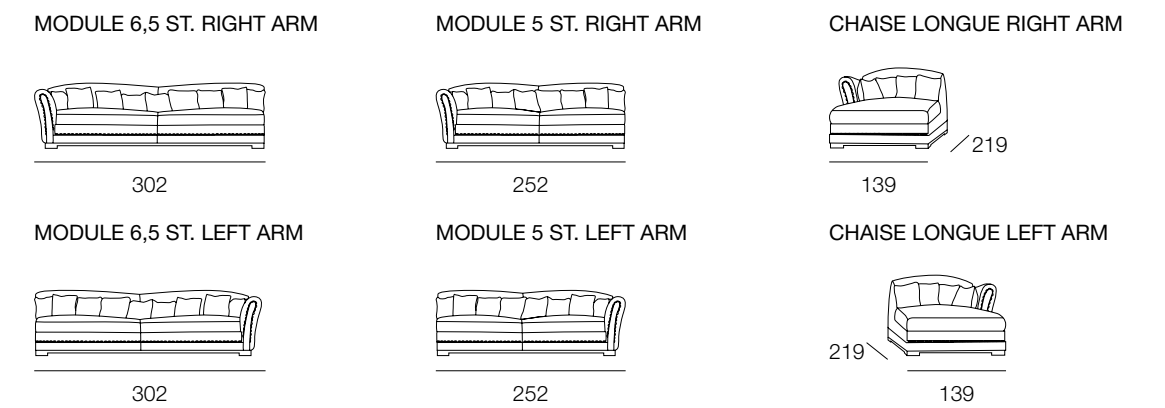





# LATORRE TECHNICAL INFORMATION

## SOFAS

### CHARLES MODULAR design Guillermo T

pag: 108-109

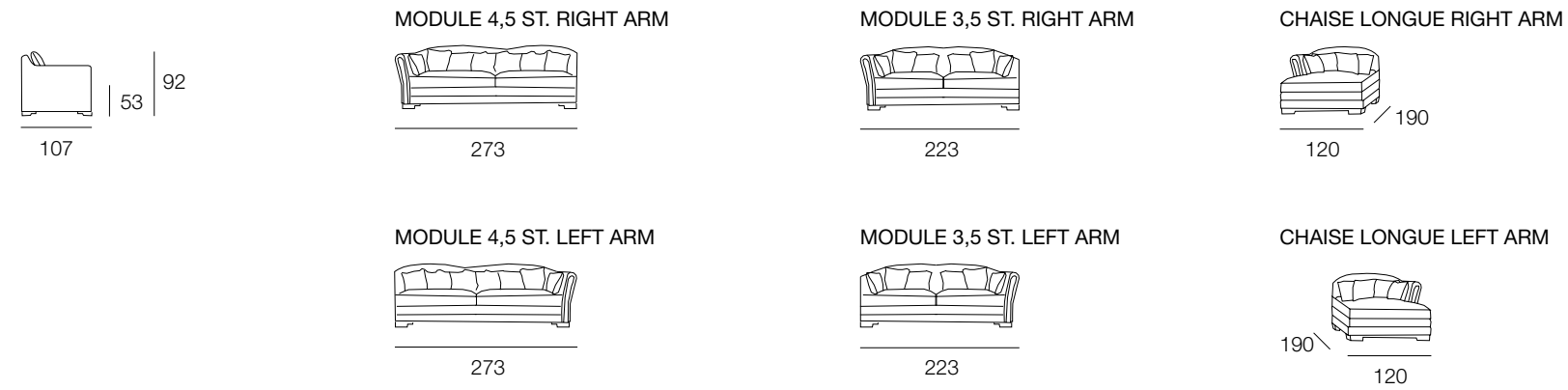

EXAMPLES:



### CHARLES BED design Guillermo T

pag: 104-105



### SIMPSON COUNTRY design Guillermo T

pag: 118-127



### MORRISON COUNTRY design Guillermo T

pag: 128-131

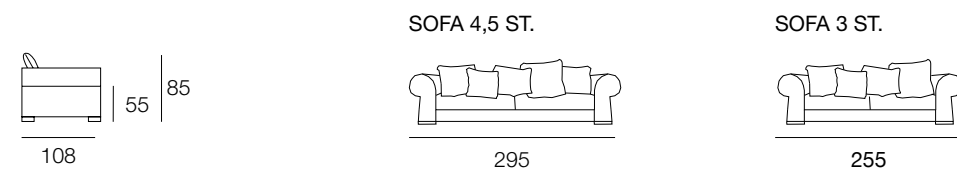

### VENDÔME design Guillermo T

pag: 132-139

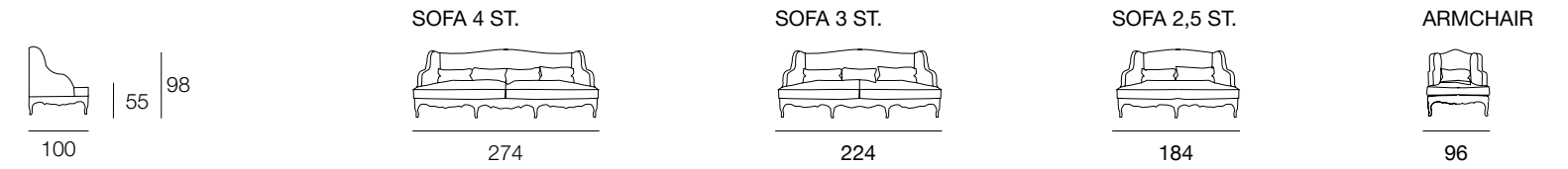

## CHAISE LONGUES

### DIVA

design Guillermo T

pag: 144-149

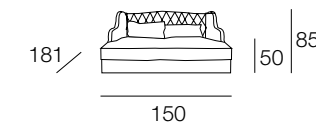

### LONG GROUND

Latorre Design Department

pag: 150-151

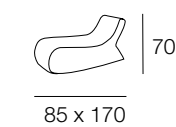

### FLANDES COUNTRY

design Guillermo T

pag: 152-153

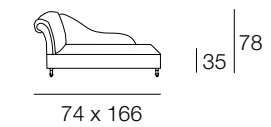

### MINI DIVAN

Latorre Design Department

pag: 154-155

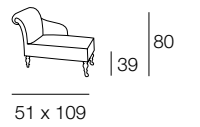

## WINGCHAIRS

### MONTGOMERY

design Guillermo T

pag: 158-161

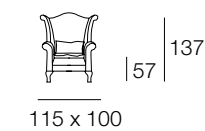

### GREENWICH

design Guillermo T

pag: 162-165

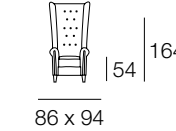

### GEORGES

Latorre Design Department

pag: 166-167

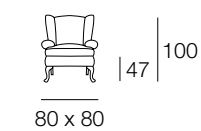

### EARTH

design Guillermo T

pag: 168-171

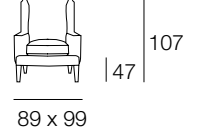

### FOOTSTOOL

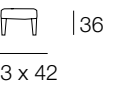

### MAXI TOMS COUNTRY

design Guillermo T

pag: 172-173

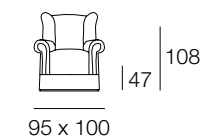

### WALTER LOVE SEAT

design Guillermo T

pag: 174-175

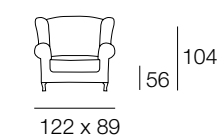





LATORRE TECHNICAL INFORMATION

ARMCHAIRS & EASY CHAIRS

DELANOIS  
design Guillermo T

pag: 178-181

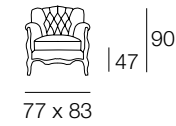

ANDREW  
Latorre Design Department

pag: 182-185



LOW NIGHTINGALE  
design Carlos Mayoral

pag: 064 / 186-187 / 287

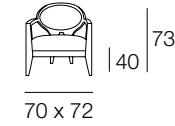

ODENSE  
design Guillermo T

pag: 014-015 / 188-189

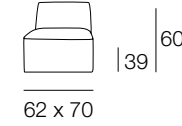

ÉLYSÉE  
design Guillermo T

pag: 190-193

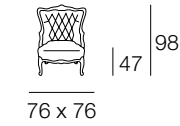

TRUMAN  
Latorre Design Department

pag: 194-195

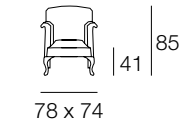

BRIGHTON  
Latorre Design Department

pag: 196-197

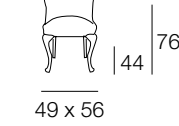

LAND  
design Guillermo T

pag: 198-199

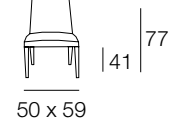

FOOTSTOOL

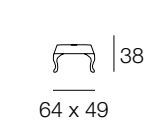

COFFEE TABLES & STOOLS

STAFFORD  
design Guillermo T

pag: 064-065 / 072 / 091-099 / 202-203

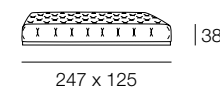

KNIGHTSBRIDGE  
design Maria José Gimeno

pag: 014 / 018 / 204-205

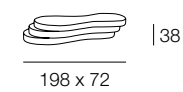

AINSLEY  
Latorre Design Department

pag: 012 / 060 / 206-207

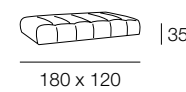

CHELSEA  
Latorre Design Department

pag: 108 / 208-211

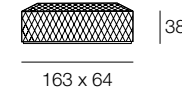

DOLOMITA  
design Macalula

pag: 075-076 / 080 / 164 / 212-213

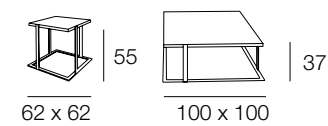

MARMORE  
design Macalula

pag: 214-215 / 268 / 269 / 295

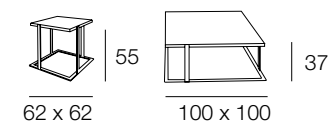

VERMONT  
Latorre Design Department

pag: 010-013 / 018 - 021 / 216-217

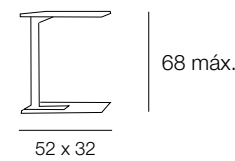

CONCORDE  
design Guillermo T

pag: 218-219 / 280

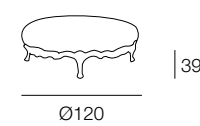

VENDÔME  
design Guillermo T

pag: 220-223 / 278

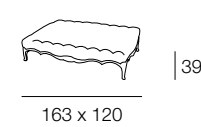

CARONTE  
design Guillermo T

pag: 224-225

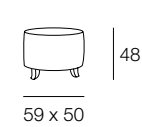

CRUZADA COUNTRY  
Latorre Design Department

pag: 226-227



DINING & BAR CHAIRS

ACANTHUS BAR  
design Guillermo T

pag: 230-231

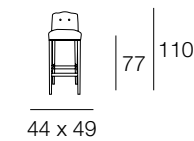

LUIS XV BAR COUNTRY  
Latorre Design Department

pag: 232-233

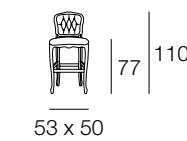

NIGHTINGALE  
design Carlos Mayoral

pag: 234-235

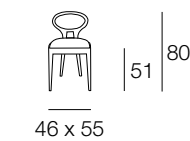

BUCKINGHAM  
Latorre Design Department

pag: 236-237 / 256

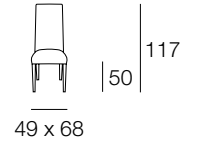

LIBERTY  
Latorre Design Department

pag: 238-239 / 256 / 260 / 288 / 292

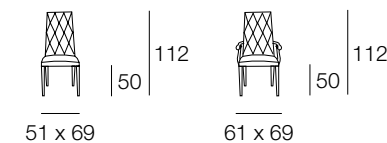

NAPOLES COUNTRY  
Latorre Design Department

pag: 240-241

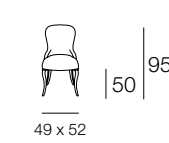

ALBERT SPECIAL  
design Guillermo T

pag: 242-245

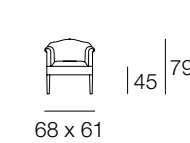

OSLO COUNTRY  
design Guillermo T

pag: 246-249

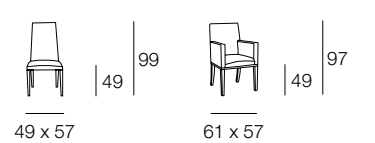

TABLES

GOLDENEYE  
design Maria José Gimeno

pag: 252-253

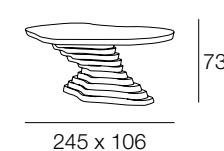

HEATHROW  
design Guillermo T

pag: 254-257 / 288

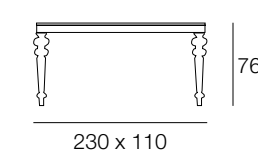

PROTOCOLO  
design Macalula

pag: 084 / 092 / 230 / 238 / 258-261 / 292

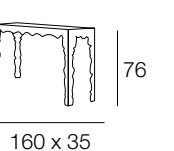
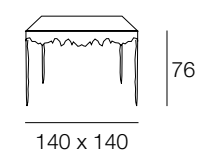
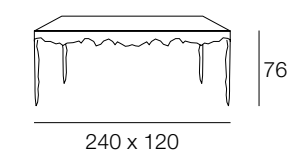





## LATORRE TECHNICAL INFORMATION

### MIRRORS

**ALAIN**  
design Guillermo T

pag: 270-271

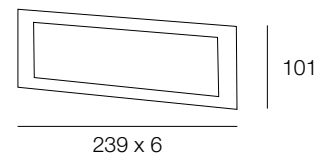

**MR. BOJANGLES**  
design Guillermo T

pag: 272-273

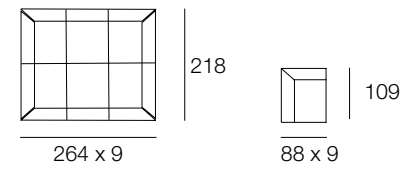

**MISS JONES**  
design Guillermo T

pag: 274-275

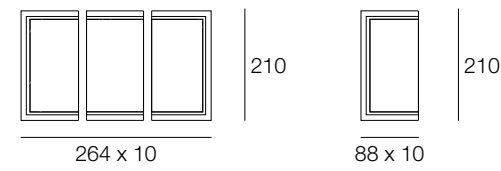

### CARPETS

**GENTLEMAN**  
Latorre Design Department

pag: 276-279

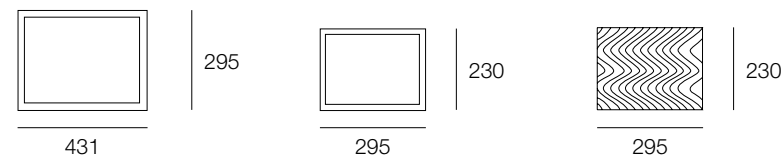

**WYNDHAM**  
design Guillermo T

pag: 186-187 / 282-283 / 287

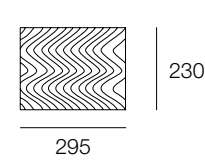

### BOOKCASE

**PRINCE**  
design Guillermo T

pag: 218 / 264-265

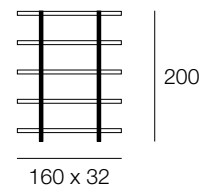

### BED

**LAUREN**  
design Guillermo T

pag: 266-267

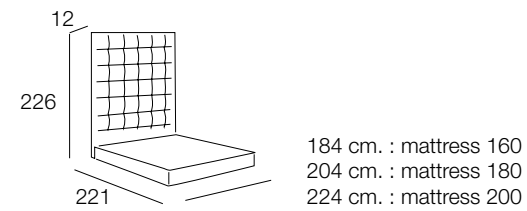

### PLAIDS

**BLACK PLAID & FUR CUSHION**  
Latorre Design Department

pag: 294-295



**WHITE PLAID & FUR CUSHION**  
Latorre Design Department

pag: 294-295



**DARK PLAID & FUR CUSHION**  
Latorre Design Department

pag: 294-295



**PALE PLAID & FUR CUSHION**  
Latorre Design Department

pag: 294-295

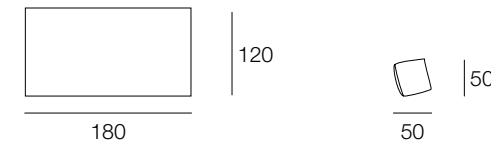

**ZEBRA RABBIT PLAID & FUR CUSHION**  
Latorre Design Department

pag: 294-295



**LINX RABBIT PLAID & FUR CUSHION**  
Latorre Design Department

pag: 294-295



### LIGHTING

**VENICE**  
Latorre Design Department

pag: 029 / 076-077 / 080-081 / 164 / 213 / 214 / 239 / 244 / 260 / 268 / 290-295

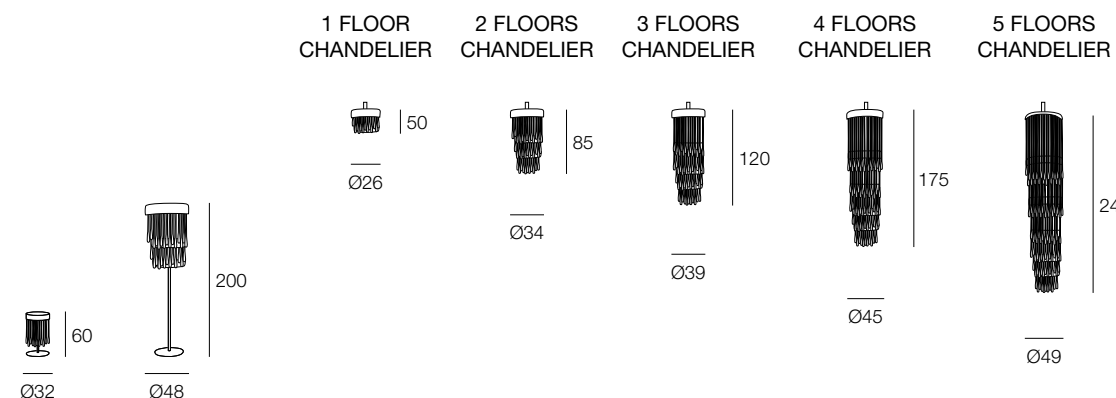

**CASANDRA**  
design OMD

pag: 064-069 / 187 / 284-287

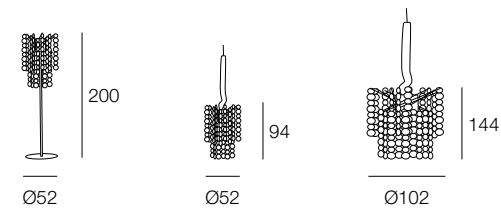

**ETNA**  
Latorre Design Department

pag: 104-105 / 256-257 / 288-289

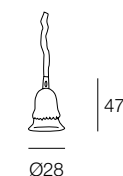

### CUSHIONS

**BOX**  
Latorre Design Department

Latorre Design Department

pag: 296-297

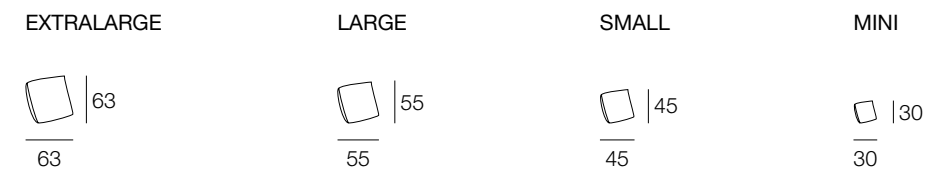

**RECTANGULAR BOX**  
Latorre Design Department

Latorre Design Department

pag: 296-297

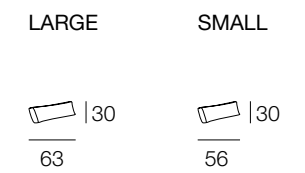

**CONTOURED CORNERS**  
Latorre Design Department

Latorre Design Department

pag: 296-297

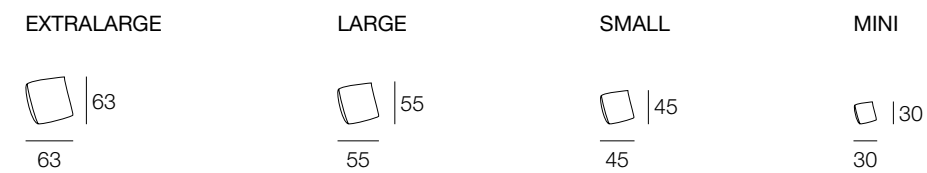

**RECTANGULAR BORDER**  
Latorre Design Department

Latorre Design Department

pag: 296-297

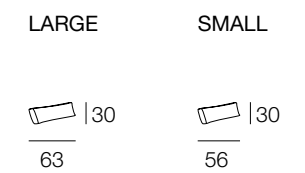

**BORDER**  
Latorre Design Department

Latorre Design Department

pag: 296-297

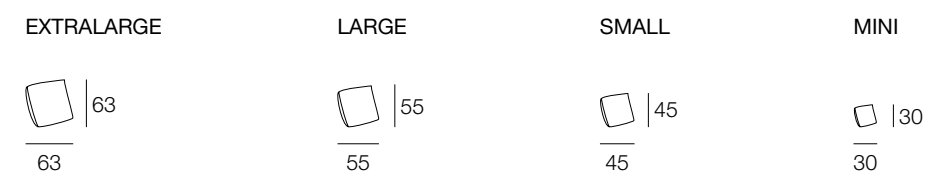

**RECTANGULAR CONTOURED CORNERS**  
Latorre Design Department

Latorre Design Department

pag: 296-297

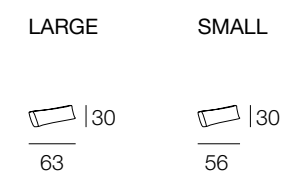





#### NOTE

ALL DRAWINGS SHOW THE STANDARD VERSION OF THE SPECIFIC PRODUCT. ALL THE DIMENSIONS SHOWN IN THE TECHNICAL DESCRIPTION ARE IN CM. AS WITH ALL HIGH QUALITY HAND-MADE UPHOLSTERY SOME TOLERANCE OF MEASUREMENTS ARE NEEDED (+/-2%). THE FABRICS SHOWN ON THE PRODUCTS IN THE PHOTOGRAPHS IN THIS CATALOGUE ARE FOR ILLUSTRATION ONLY: THE CUSTOMER CAN OF COURSE CHOOSE ANY FABRICS OR LEATHERS FROM THE SUPERB AND UNIQUE ASCENSIÓN LATORRE RANGE. THE CUSTOMER CAN INSTEAD ALSO SUPPLY THEIR OWN MATERIAL ("CUSTOMERS OWN MATERIAL": COM).

WITH ASCENSIÓN LATORRE LEATHERS AND FABRICS EVERY ATTEMPT IS MADE TO ENSURE A PERFECT COLOUR AND TEXTURE MATCH ACROSS THE PIECE OF UPHOLSTERY: BUT AS WITH ALL LEATHERS, INCLUDING THE FINE ASCENSIÓN LATORRE LEATHERS, PLEASE BE AWARE THAT DUE TO NATURAL VARIATION IN THE MANNER IN WHICH THE DYE IS ABSORBED INTO THE LEATHER DURING THE TANNING PROCESS, THERE MAY BE VARIATIONS IN SHADE AND TEXTURE WITHIN THE SAME HIDE, AND BETWEEN DIFFERENT HIDES. IT MUST BE ACCEPTED THEREFORE THAT IT MAY NOT BE POSSIBLE TO ACHIEVE A UNIFORM MATCH BETWEEN PANELS THAT ARE JOINED TOGETHER. ALSO DUE TO THE PROCESS IN DYEING FABRICS, THERE CAN BE SMALL VARIATIONS BETWEEN ONE DYED FABRIC BATCH AND ANOTHER.

YOU WILL NOTICE THAT MANY OF OUR PRODUCTS HAVE WONDERFUL STUDDING DETAILS AROUND THE EDGES OF THE UPHOLSTERY – CHROMED OR DARK BRASS STUDDING. THESE STUDS CANNOT BE APPLIED TO ALL PIECES OF UPHOLSTERY, IT WILL DEPEND ON EACH MODEL. PLEASE, CONSULT WITH US BEFORE CONFIRMING YOUR ORDER REGARDING THIS.

THE COMPANY RESERVES THE RIGHT TO CHANGE THE TECHNICAL SPECIFICATION OF THE PRODUCTS SHOWN IN THIS CATALOGUE WITHOUT NOTICE (AS A RESULT OF TECHNICAL UPDATES AND IMPROVEMENTS). IN THIS CATALOGUE, THE REFERENCE DIMENSIONS ARE AS FOLLOWS:

#### NOTA

LOS DIBUJOS MUESTRAN LA VERSIÓN ESTANDAR. TODAS LAS DIMENSIONES INCLUIDAS EN LAS DESCRIPCIONES TÉCNICAS ESTAN EXPRESADAS EN CM., SON APROXIMADAS Y ESTAN SUJETAS A CAMBIOS (CON UNA TOLERANCIA DEL 2%). LOS PRODUCTOS MOSTRADOS EN LAS FOTOS NO TIENEN UN TAPIZADO ESTANDAR. DEPENDIENDO DEL MODELO, LOS PRODUCTOS PUEDEN SER FABRICADOS EN TELA Y/O PIEL DE LOS MUESTRARIOS OFICIALES DE ASCENSIÓN LATORRE / PAU O EN TELA Y/O PIEL DEL CLIENTE.

DEBIDO A LA VARIACIÓN NATURAL EN LA MANERA EN QUE EL TINTE ES ABSORBIDO POR LA PIEL DURANTE EL PROCESO DE CURTIDO ESTOS PUEDEN MOSTRAR VARIACIONES EN FORMA DE SOMBRAS Y TEXTURAS DENTRO DE LA MISMA PIEL. SE DEBE ACEPTAR, ASIMISMO, QUE TAL VEZ NO SEA POSIBLE ALCANZAR UNA CONCORDANCIA UNIFORME ENTRE DIFERENTES PIELES DEL MISMO MODELO UNIDAS. DEBIDO AL PROCESO EN EL TINTADO DE LOS TEJIDOS, ÉSTOS PUEDEN PRESENTAR CAMBIOS DE UNA TINTADA A OTRA.

NO TODAS LAS TACHUELAS EN CUALQUIER DIMENSIÓN PUEDEN SER APLICADAS A TODOS NUESTROS MODELOS. DEPENDERÁ DE SU ESTRUCTURA. POR FAVOR, CONSULTE CON NOSOTROS ANTES DE REALIZAR SU PEDIDO.

LA EMPRESA SE RESERVA EL DERECHO A CAMBIAR LAS CARACTERÍSTICAS TÉCNICAS DE LOS PRODUCTOS MOSTRADOS EN ESTE CATÁLOGO, SIN PREVIO AVISO, COMO RESULTADO DE ACTUALIZACIONES TÉCNICAS. POR FAVOR TENGA EN CUENTA QUE, EN ESTE CATÁLOGO, LAS DIMENSIONES ESTAN EXPRESADAS COMO SIGUE:

#### NOTE

LES DESSINS TECHNIQUES REPRÉSENTENT LA VERSION STANDARD DES MODÈLES. TOUTES LES DIMENSIONS INDIQUÉES DANS LA DESCRIPTION TECHNIQUE SONT EXPRIMÉES EN CM. (ELLES PEUVENT ÊTRE SUJETTES À UNE VARIATION DE 2%). LES MODÈLES REPRÉSENTÉS SUR LES PHOTOS PEUVENT ÊTRE RECOUVERTS DE TISSUS, CUIRS ET PEAUX QUE VOUS TROUVEREZ DANS LES DIFFÉRENTES COLLECTIONS D'ASCENSIÓN LATORRE OU DANS LA SÉLECTION POUR LES MODÈLES CONTEMPORAINS DE PAUDESIGN. VOUS POUVEZ AUSSI ENVOYER VOS PROPRES TISSUS.

CONCERNANT LES TISSUS, IL EXISTE RÉGULIÈREMENT DES DIFFÉRENCES DE BAINS ENTRE L'ÉCHANTILLON PRÉSENTÉ SUR LES COLLECTIONS ET LE MÉTRAGE COMMANDÉ. CERTAINS VELOURS "FRAPPÉS" PRÉSENTENT DES FINITIONS À LA MAIN OÙ LES EFFETS DE BRILLANCE NE SONT PAS UNIFORMES. C' EST LE CHARME DE CES ÉTOFFES. POUR DES RAISONS DE QUALITÉ DE FINITION, NOUS ÉVITONS DE RÉALISER DES SOFAS DÉHOUSSABLES EN VELOURS. LES CUIRS ET PEAUX PEUVENT SUBIR DES VARIATIONS DE TONS SUR UNE MÊME PIÈCE CAR LES COLORANTS PEUVENT RÉAGIR DIFFÉREMMENT SUR DES TEXTURES NATURELLES. TOUTE RÉCLAMATION CONCERNANT DES CUIRS OU DES PEAUX AVEC DES VARIATIONS DE TEINTES NE SERA PAS ACCEPTÉE.

DE NOMBREUX MODÈLES PEUVENT RECEVOIR LES FINITIONS AVEC DES CLOUS DE DIFFÉRENTS DIAMÈTRES, NOUS VOUS DEMANDONS DE NOUS CONSULTER POUR CETTE FINITION.

NOTRE SOCIÉTÉ SE RÉSERVE LE DROIT D'APPORTER DES MODIFICATIONS TECHNIQUES SUR LES MODÈLES PRÉSENTÉS DANS LE CATALOGUE SANS AVIS PRÉALABLE. CES MODIFICATIONS SERONT DES AMÉLIORATIONS TECHNIQUES. LES DIMENSIONS DE REFERENCE SONT EXPRIMÉES DE LA FAÇON SUIVANTE:

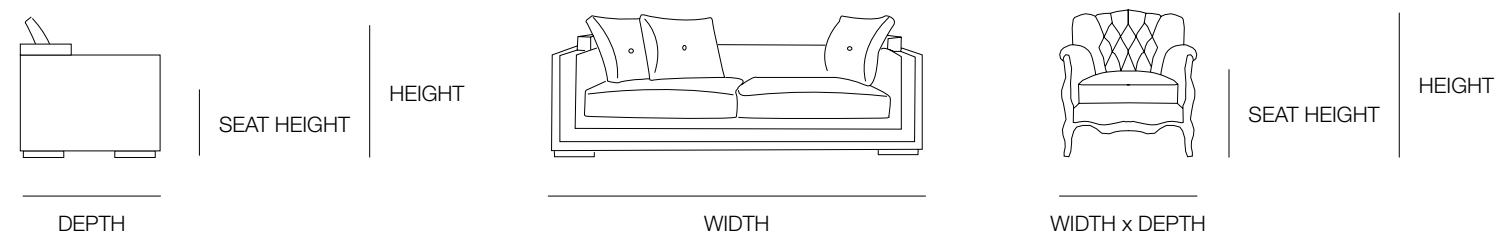









[www.ascensionlatorre.com](http://www.ascensionlatorre.com)